



STEEL FRAMING

BUILDSMART®

Interior Framing Products Catalog Standard Non-Structural Stud and Track



Table of Contents

General Product and Catalog Information	3	Limiting Wall Heights - Non-Composite	
Product Certifications	4	Standard Non-Equivalent Products	19 - 26
General Product Type Information	5	Ceiling Spans	
Standard Non-Structural Product Information		Ceiling Span Diagrams	27
Standard Non-Equivalent Products	6 - 9	Standard Non-Equivalent Products	28 - 30
- 20ga Standard (30mil)		Web Crippling	
- 22ga Standard (27mil)		Web Crippling Conditions	31
- 25ga Standard (18mil)		Standard Non-Equivalent Products	32
- 20ga Standard (33mil)		Allowable Screw Connection Capacity	33
Slotted Deflection Track	10 - 11	Accessories	
Notes / Definitions		Accessories Overview	34
General Notes for all Tables	12	U-Channel	35
Section Properties		Furring (Hat) Channel	36 - 37
Standard Non-Equivalent Products	13 - 14	Z-Furring	38
Slotted Deflection Track	15	Angle	38
Limiting Wall Heights Overview	16	Flat Stock	38
Limiting Wall Heights - Composite		Resilient Channl (RC-1)	38
Standard Non-Equivalent Products	17 - 18	Legal Information	39

MRI Corporate Headquarters

15 Salt Creek Lane, Suite 412
Hinsdale, IL 60521
Phone: (630) 616-1850
Fax: (630) 568-5979

Production Facility

1225 Martin Luther King Dr
Gary, IN 46402
Phone: (630) 616-1850
Fax: (219) 886-3341



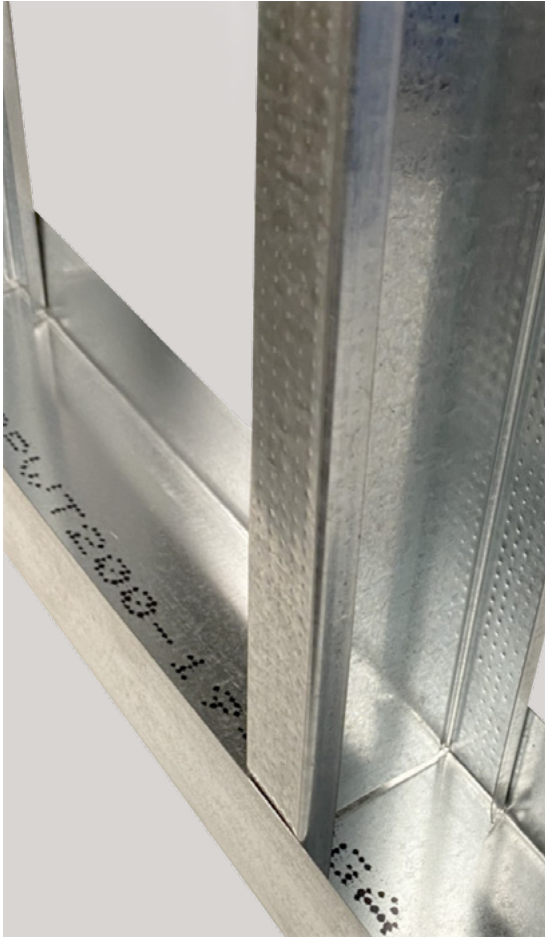

The purpose of this catalog is to introduce transparency and clarity into the designing and building of non-load bearing, interior partition and ceiling applications. There has been much confusion and frustration with the introduction of "Equivalent" products and how they perform in certain wall applications or under certain conditions. We are on a mission to clarify how **MRI Steel Framing** interior products perform so the contractor has options when comparing project requirements with product performance.

MRI Steel Framing has been making full weight non-equivalent interior drywall products since 2004. We produce Standard drywall products (30mil, 27mil and 18mil) that are manufactured true to gauge for all the strength you need, the performance you expect, and the safe, proven, functionality your project demands. The MRI 30mil product is the flagship of our interior drywall product line and is the product of choice for contractors looking for an interior stud that does it all.

MRI Steel Framing also produces two lines of "Equivalent" products in 27mil and 19/21mil versions. On projects where "EQ" products are accepted, contractors now have a choice and can choose our 27mil MRI Smart® 20ga EQ Stud or our new 19/21mil PrimeWall® 20ga EQ Stud. Both "EQ" products are excellent choices that outperform our competitor's "EQ" studs in many interior applications.

MRI has made a concerted effort to ensure the accuracy of the information represented in this catalog. However, this information should not be used in design or construction without an independent evaluation by a qualified engineer or architect. This publication contains the latest information available at the time of printing. MRI reserves the right to make modifications and/or change materials of any product without prior notice or obligation.

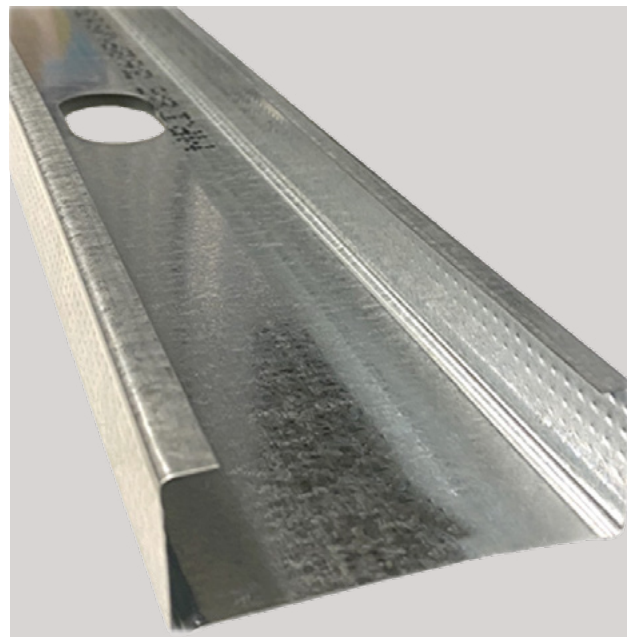



Find us in
MasterSpec®
Powered by Deltek Specpoint®



SpecLink



MRI Steel Framing building products are manufactured to meet or exceed all applicable standards including:

AISI S100-2016. North American Specification for the Design of Cold-Formed Steel Structural Members.

IBC 2018. International Building Code – 2018.

AISI S220-2015. North American Standard for Cold-Formed Steel Framing – Nonstructural Members.

ASTM A1003. Standard Specification for Steel Sheet, Carbon, Metallic and Nonmetallic Coated for Cold Formed Framing Members.

ASTM A653. Standard Specification for Steel Sheet, Zinc-Coated (Galvanized) or Zinc-Iron Alloy-Coated (Galvannealed) by the Hot-Dip Process.

ASTM C645. Standard Specification for Nonstructural Steel Framing Members.

ASTM C754. Standard Specification for Installation of Steel Framing Members to Receive Screw-Attached Gypsum Panel Products.

ASTM E72. Standard Test Methods of Conducting Strength Tests of Panels for Building Construction.

ASTM E90. Standard Test Method for Laboratory Measurement of Airborne Sound Transmission Loss of Building Partitions and Elements.

LEED® v4 Information:

- EPD (SCS-EPD-07103)
- HPD (27459)
- SDS Sheets

For more Leed® details contact MRI Customer Service.

MRI Steel Framing products are also listed in the following:

- ICC ES Evaluation Report ESR-4205
- CCRR-0224 (through association with SFIA)
- UL Fire Listed through the SFIA

MRI Steel Framing Products are Certified

MRI Steel Framing is a proud member of the SFIA (Steel Framing Industry Association) and the products included in the catalog are certified by the SFIA to ensure consistent quality and compliance to all applicable industry standards via unannounced 3rd party independent testing.

MRI Steel Framing Stud Profiles

Standard Non-Structural Stud

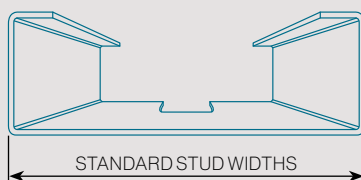

MRI Smart® 20 EQ Stud

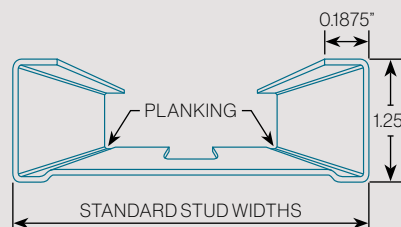

PrimeWall® 20 EQ Stud

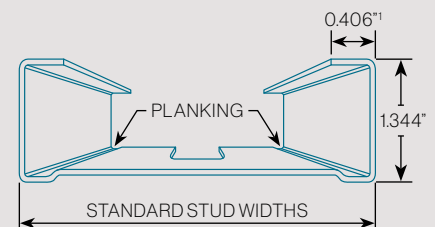

¹ 0.25" RETURN ON 1.625" STUDS

General Product Type Information

Member/Web Measurement		Product Style	Flange/Leg Measurement	Material Thickness	
600		S	125 - 30		
Web Measurement	Product Style	Flange/Leg Measurement	(Mils)	Material Thickness	
				Design Thickness (in)	Minimum Thickness (in)
162 = 1.625"	S = Stud	125 = 1.25"	18	0.0188	0.0179
250 = 2.5"	SES = MRI Smart® 20 EQ Stud	150 = 1.5"	19	0.0200	0.0190
350 = 3.5"	PWS = PrimeWall® 20 EQ Stud	200 = 2.0"	21	0.0221	0.0210
362 = 3.625"	T = Track	300 = 3.0"	27	0.0283	0.0269
400 = 4.0"	SET = MRI Smart® 20 EQ Track		30	0.0312	0.0296
550 = 5.5"	PWT = PrimeWall® 20 EQ Track		33	0.0346	0.0329
600 = 6.0"	SLT = Slotted Track				

General Product Types							
Product Type	Gauge	Yield (Fy) (KSI)	Designation Thickness (mils)	Design Thickness (in)	Minimum Thickness (in)	Design Inside Corner Radii (in)	Color
Standard NS	20ga	33	30	0.0312	0.0296	0.0782	Pink
Standard NS	22ga	33	27	0.0283	0.0269	0.0796	Black
Standard NS	25ga	33	18	0.0188	0.0179	0.0844	(none)
Standard NS	20ga ST	33	33	0.0346	0.0329	0.0765	White
MRI Smart® 20 EQ	20ga EQ	43	27	0.0283	0.0269	0.0796	Black
PrimeWall® 20 EQ	20ga EQ	55	19/21	0.020/0.022	0.019/0.021	0.0680	Brown

- MRI nonstructural framing products have a G40 coating or a minimum standard coating that complies with the requirements of IBC 2018 and ASTM A1003/ A1003M. G60 and G90 coatings are available upon request.
- MRI nonstructural framing products will comply with the manufacturing tolerances listed in ASTM C645. (Table 1 Manufacturing Tolerances for non-structural members).
- Groups of like members will be color-coded during the manufacturing process and each framing member will be marked appropriately so that products can be easily identified in the field.

General Non-Equivalent Product Information

MRI manufactures Standard interior drywall products in **20ga ST (33 mil)**, **20ga (30 mil)**, **22ga (27mil)** and **25ga (18mil)** thicknesses. True to Gauge products have proven themselves as having the performance criteria needed to meet your project's tough design requirements. In non-composite wall applications, our standard full weight products outperform all interior "EQ" products on the market today, including our own PrimeWall® EQ stud. Non-Equivalent studs are the product of choice for non-composite wall applications, especially with higher limiting height requirements. True to gauge products have historical data proving themselves superior in interior wall applications needing higher performing products with the strength you need, the performance you expect, and the safe, proven, functionality your project demands.

Standard 20ga (30mil) Products

Standard 30mil studs are proven to be the most versatile interior framing products in the market today and are still the best performing studs in the industry. "EQ" products claim to be as strong as traditional 30mil products, but the fact is, they are only required to meet 1 out of 18 physical section properties of a true to gauge 30mil product. In applications needing a higher performing product, MRI 30mil products are still the product of choice by contractors throughout the metal framing industry.

Standard 30mil products are accepted and recommended by the Gypsum Association for use in impact-resistant and abuse-resistant board installations.

The architectural and engineering communities have begun to recognize the limitations of "EQ" products in certain applications, especially in Hospitals, Schools and Governmental projects where a higher performing interior stud may be needed.

Standard 25ga (18mil) Products

MRI full weight 18mil 25ga. product is approximately 20% thicker than the average 25ga "EQ" product on the market today. Our 3-5/8" 25ga product does not have web/height to thickness ratio issues like many other 3-5/8" 25ga "EQ" products, which means, in non-composite applications, you do not have to install web stiffeners at every point where the stud meets the track.

Historically, true to gauge 18mil 25ga products have proven themselves in meeting project design requirements and are the product of choice for non-composite wall applications.

In conclusion, Standard Non-Equivalent products provide the provide the highest strength and serviceability. They are the most versatile interior framing products on the market today and will perform best in, by far, the most non-composite interior wall applications in our industry with the most historical evidence to back them up.

General Non-Equivalent Product Information

Stud and Track

Manufactured true to gauge for all the strength you need, the performance you expect, and the safe, proven, functionality your project demands. MRI's standard nonstructural studs are precision manufactured to exacting tolerances that provide the framework for superior construction. You can depend on strong traditional gauge studs because true strength is measured in mils.

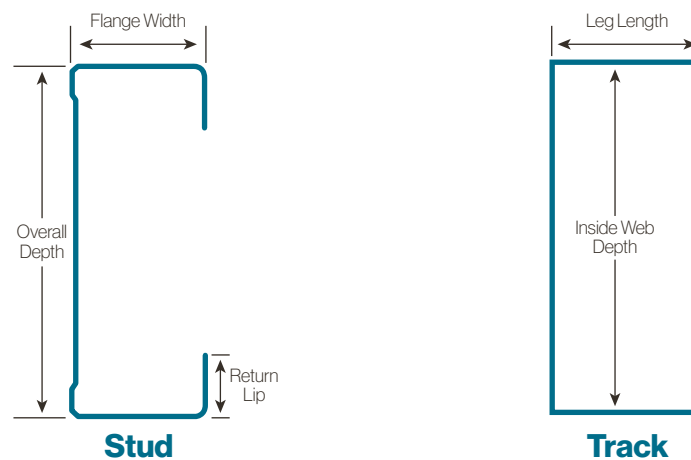

Advantages of this Product:

- The highest limiting heights for 20ga products in non-composite wall applications.
- No "web-height to thickness ratio" limitations for 30mil products. That means no web stiffeners are needed.
- 30mil products are being specified more often in applications requiring a higher performing product, such as in hospitals, schools, government projects, etc.
- There is massive historical data on 30mil products that support how these products meet strict performance criteria.
- The Gypsum Association recommends 30mil products with A/R and I/R gypsum panels.

Standard Non-Equivalent Stud

- Width: 1-5/8", 2-1/2", 3-1/2", 3-5/8", 4", 5-1/2", 6"
- Flange: 1-1/4"
- Return Lip: 3/16"
- Gauges: 25ga (18mil), 22ga (27mil), 20ga (30mil), 20ga ST (33mil)
- These products will have a minimum standard yield strength of 33 KSI
- These products will have a G40 coating or a minimum standard coating that complies with the requirements of IBC 2018 and ASTM A1003/ A1003M. G60 and G90 coatings are available upon request.

Standard Non-Equivalent Track

- Width: 1-5/8", 2-1/2", 3-1/2", 3-5/8", 4", 5-1/2", 6"
- Leg Lengths: 1-1/4", 1-1/2", 2", 2-1/2", 3"
- Gauges: 25ga (18mil), 22ga (27mil), 20ga (30mil), 20ga ST (33mil)
- These products will have a minimum standard yield strength of 33 KSI
- These products will have a G40 coating or a minimum standard coating that complies with the requirements of IBC 2018 and ASTM A1003/ A1003M. G60 and G90 coatings are available upon request.

General Product Information

Standard Non-Equivalent • Drywall Framing Stud											
Standard Non-Structural Stud	Material Requirements				Product Measurements						Color Coding
	Yield (KSI)	Mil Thickness	Design Thickness	Base Metal Thickness	Web (nominal)		Leg / Flange		Return / Lip		
					Decimal	Fraction	Decimal	Fraction	Decimal	Fraction	
162S125-18	33	18	0.0188	0.0179	1.625"	1-5/8"	1.25"	1-1/4"	0.188"	3/16"	(none)
250S125-18	33	18	0.0188	0.0179	2.5"	2-1/2"	1.25"	1-1/4"	0.188"	3/16"	(none)
350S125-18	33	18	0.0188	0.0179	3.5"	3-1/2"	1.25"	1-1/4"	0.188"	3/16"	(none)
362S125-18	33	18	0.0188	0.0179	3.625"	3-5/8"	1.25"	1-1/4"	0.188"	3/16"	(none)
400S125-18	33	18	0.0188	0.0179	4"	4"	1.25"	1-1/4"	0.188"	3/16"	(none)
550S125-18	33	18	0.0188	0.0179	5.5"	5-1/2"	1.25"	1-1/4"	0.188"	3/16"	(none)
600S125-18	33	18	0.0188	0.0179	6"	6"	1.25"	1-1/4"	0.188"	3/16"	(none)
162S125-27	33	27	0.0283	0.0269	1.625"	1-5/8"	1.25"	1-1/4"	0.188"	3/16"	Black
250S125-27	33	27	0.0283	0.0269	2.5"	2-1/2"	1.25"	1-1/4"	0.188"	3/16"	Black
350S125-27	33	27	0.0283	0.0269	3.5"	3-1/2"	1.25"	1-1/4"	0.188"	3/16"	Black
362S125-27	33	27	0.0283	0.0269	3.625"	3-5/8"	1.25"	1-1/4"	0.188"	3/16"	Black
400S125-27	33	27	0.0283	0.0269	4"	4"	1.25"	1-1/4"	0.188"	3/16"	Black
550S125-27	33	27	0.0283	0.0269	5.5"	5-1/2"	1.25"	1-1/4"	0.188"	3/16"	Black
600S125-27	33	27	0.0283	0.0269	6"	6"	1.25"	1-1/4"	0.188"	3/16"	Black
162S125-30	33	30	0.0312	0.0296	1.625"	1-5/8"	1.25"	1-1/4"	0.188"	3/16"	Pink
250S125-30	33	30	0.0312	0.0296	2.5"	2-1/2"	1.25"	1-1/4"	0.188"	3/16"	Pink
350S125-30	33	30	0.0312	0.0296	3.5"	3-1/2"	1.25"	1-1/4"	0.188"	3/16"	Pink
362S125-30	33	30	0.0312	0.0296	3.625"	3-5/8"	1.25"	1-1/4"	0.188"	3/16"	Pink
400S125-30	33	30	0.0312	0.0296	4"	4"	1.25"	1-1/4"	0.188"	3/16"	Pink
550S125-30	33	30	0.0312	0.0296	5.5"	5-1/2"	1.25"	1-1/4"	0.188"	3/16"	Pink
600S125-30	33	30	0.0312	0.0296	6"	6"	1.25"	1-1/4"	0.188"	3/16"	Pink
162S125-33	33	33	0.0346	0.0329	1.625"	1-5/8"	1.25"	1-1/4"	0.188"	3/16"	White
250S125-33	33	33	0.0346	0.0329	2.5"	2-1/2"	1.25"	1-1/4"	0.188"	3/16"	White
350S125-33	33	33	0.0346	0.0329	3.5"	3-1/2"	1.25"	1-1/4"	0.188"	3/16"	White
362S125-33	33	33	0.0346	0.0329	3.625"	3-5/8"	1.25"	1-1/4"	0.188"	3/16"	White
400S125-33	33	33	0.0346	0.0329	4"	4"	1.25"	1-1/4"	0.188"	3/16"	White
550S125-33	33	33	0.0346	0.0329	5.5"	5-1/2"	1.25"	1-1/4"	0.188"	3/16"	White
600S125-33	33	33	0.0346	0.0329	6"	6"	1.25"	1-1/4"	0.188"	3/16"	White

Standard Non-Equivalent Products

General Product Information

Standard Non-Equivalent • Drywall Framing Track					
Standard Non-Structural Stud	Yield (KSI)	Product Measurements			
		Web (nominal)		Leg / Flange	
		Decimal	Fraction	Decimal	Fraction
162T125-18,27,30,33	33	1.625"	1-5/8"	1.25"	1-1/4"
162T150-18,27,30,33	33	1.625"	1-5/8"	1.50"	1-1/2"
250T125-18,27,30,33	33	2.5"	2-1/2"	1.25"	1-1/4"
250T150-27,30,33	33	2.5"	2-1/2"	1.50"	1-1/2"
250T200-33	33	2.5"	2-1/2"	2.00"	2"
350T125-18,27,30,33	33	3.5"	3-1/2"	1.25"	1-1/4"
350T150-27,30,33	33	3.5"	3-1/2"	1.50"	1-1/2"
350T200-33	33	3.5"	3-1/2"	2.00"	2"
350T250-33	33	3.5"	3-1/2"	2.50"	2-1/2"
350T300-33	33	3.5"	3-1/2"	3.00"	3"
362T125-18,27,30,33	33	3.625"	3-5/8"	1.25"	1-1/4"
362T150-27,30,33	33	3.625"	3-5/8"	1.50"	1-1/2"
362T200-33	33	3.625"	3-5/8"	2.00"	2"
362T250-33	33	3.625"	3-5/8"	2.50"	2-1/2"
362T300-33	33	3.625"	3-5/8"	3.00"	3"
400T125-18,27,30,33	33	4.0"	4"	1.25"	1-1/4"
400T150-27,30,33	33	4.0"	4"	1.50"	1-1/2"
400T200-33	33	4.0"	4"	2.00"	2"
400T250-33	33	4.0"	4"	2.50"	2-1/2"
400T300-33	33	4.0"	4"	3.00"	3"
550T125-27,30,33	33	5.5"	5-1/2"	1.25"	1-1/4"
550T150-27,30,33	33	5.5"	5-1/2"	1.50"	1-1/2"
550T200-33	33	5.5"	5-1/2"	2.00"	2"
550T250-33	33	5.5"	5-1/2"	2.50"	2-1/2"
550T300-33	33	5.5"	5-1/2"	3.00"	3"
600T125-27,30,33	33	6.0"	6"	1.25"	1-1/4"
600T150-27,30,33	33	6.0"	6"	1.50"	1-1/2"
600T200-33	33	6.0"	6"	2.00"	2"
600T250-33	33	6.0"	6"	2.50"	2-1/2"
600T300-33	33	6.0"	6"	3.00"	3"

General Product Information

Deflection track may be required at the top of a wall to allow the wall stud to float within the top track legs. This allows for a vertical live load movement of the primary structure. A gap is provided between the end of the stud and the track to allow this movement. MRI Steel Framing deflection track is available with leg lengths of 2-1/2", 3" and 3-1/2".

Product/Web Sizes (nominal):

2.50" Minimum
16.00" Maximum

Leg / Slot Sizes:

2.50" / 1.50"
3.00" / 2.00"
3.50" / 2.50"
4.00" / 3.00"

Material Gauges:

.0188 Minimum (25ga)
.0713 Maximum (14ga)

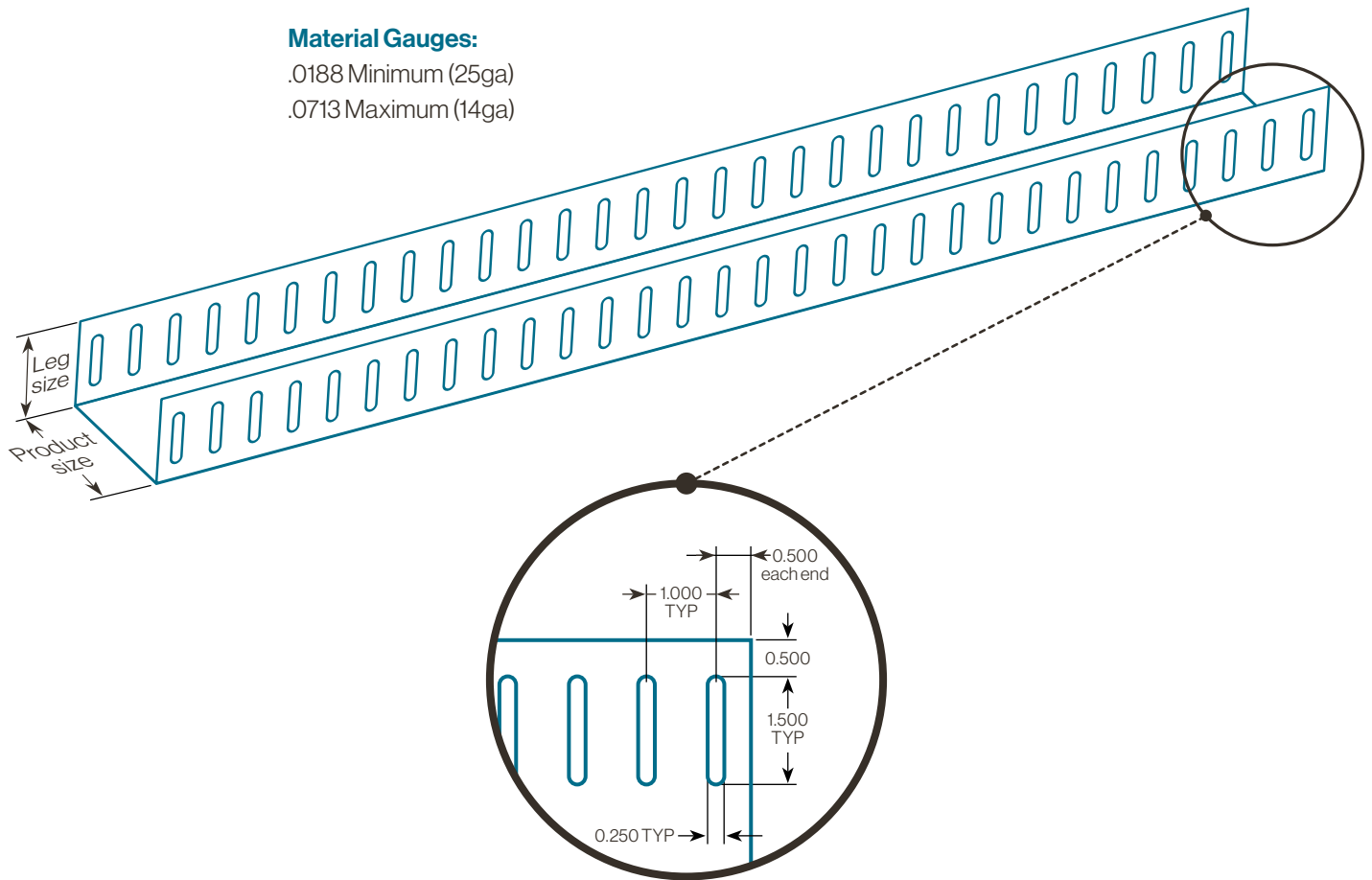

Note: Detail represents 2-1/2" track

Slotted Deflection Track

General Product Information

Standard Non-Equivalent • Drywall Framing Track								
Part Number	Leg Size	Slot Size	Web Size	Gauge	Design Thickness	Minimum Thickness	Yield (KSI)	Coating
250SLT250-18	2-1/2"	1-1/2"	2-1/2"	25	.0188"	.0179"	33	G40
250SLT250-30	2-1/2"	1-1/2"	2-1/2"	20 (drywall)	.0312"	.0296"	33	G40
250SLT250-33	2-1/2"	1-1/2"	2-1/2"	20 (structural)	.0346"	.0329"	33	G60
362SLT250-18	2-1/2"	1-1/2"	3-5/8"	25	.0188"	.0179"	33	G40
362SLT250-30	2-1/2"	1-1/2"	3-5/8"	20 (drywall)	.0312"	.0296"	33	G40
362SLT250-33	2-1/2"	1-1/2"	3-5/8"	20 (structural)	.0346"	.0329"	33	G60
362SLT300-30	3"	2"	3-5/8"	20 (drywall)	.0312"	.0296"	33	G40
362SLT300-33	3"	2"	3-5/8"	20 (structural)	.0346"	.0329"	33	G60
362SLT350-30	3-1/2"	2-1/2"	3-5/8"	20 (drywall)	.0312"	.0296"	33	G40
362SLT350-33	3-1/2"	2-1/2"	3-5/8"	20 (structural)	.0346"	.0329"	33	G60
400SLT250-18	2-1/2"	1-1/2"	4"	25	.0188"	.0179"	33	G40
400SLT250-30	2-1/2"	1-1/2"	4"	20 (drywall)	.0312"	.0296"	33	G40
400SLT250-33	2-1/2"	1-1/2"	4"	20 (structural)	.0346"	.0329"	33	G60
400SLT300-30	3"	2"	4"	20 (drywall)	.0312"	.0296"	33	G40
400SLT300-33	3"	2"	4"	20 (structural)	.0346"	.0329"	33	G60
400SLT350-30	3-1/2"	2-1/2"	4"	20 (drywall)	.0312"	.0296"	33	G40
400SLT350-33	3-1/2"	2-1/2"	4"	20 (structural)	.0346"	.0329"	33	G60
600SLT250-18	2-1/2"	1-1/2"	6"	25	.0188"	.0179"	33	G40
600SLT250-30	2-1/2"	1-1/2"	6"	20 (drywall)	.0312"	.0296"	33	G40
600SLT250-33	2-1/2"	1-1/2"	6"	20 (structural)	.0346"	.0329"	33	G60
600SLT300-30	3"	2"	6"	20 (drywall)	.0312"	.0296"	33	G40
600SLT300-33	3"	2"	6"	20 (structural)	.0346"	.0329"	33	G60
600SLT350-30	3-1/2"	2-1/2"	6"	20 (drywall)	.0312"	.0296"	33	G40
600SLT350-33	3-1/2"	2-1/2"	6"	20 (structural)	.0346"	.0329"	33	G60
800SLT250-30	2-1/2"	1-1/2"	8"	20 (drywall)	.0312"	.0296"	33	G40
800SLT250-33	2-1/2"	1-1/2"	8"	20 (structural)	.0346"	.0329"	33	G60
800SLT300-30	3"	2"	8"	20 (drywall)	.0312"	.0296"	33	G40
800SLT300-33	3"	2"	8"	20 (structural)	.0346"	.0329"	33	G60
800SLT350-30	3-1/2"	2-1/2"	8"	20 (drywall)	.0312"	.0296"	33	G40
800SLT350-33	3-1/2"	2-1/2"	8"	20 (structural)	.0346"	.0329"	33	G60

Larger sizes are available upon request.

General Notes for All Tables

1. Calculations are based on AISI Standard, North American Specification for the Design of Cold-Formed Steel Structural Members, 2016 edition (AISI S100-2016) unless otherwise noted. All calculations are based on allowable strength design (ASD).
2. The strength increase from cold work of forming has been incorporated for flexural strength per AISI S100, A7.2
3. When provided, factory punchouts will be located along the centerline of the webs of the members and will have a minimum center-to-center spacing of 24 inches. Punchouts for members > 2.5 inches deep are a maximum of 1.5 inches wide x 4 inches long. Members with depths 2.5" and smaller are maximum 3/4" wide x 4 inches long.

Definitions of Structural Property Symbols

Gross Properties

- I_{xx}** : Moment of inertia of the gross section about the X-X axis (strong axis).
 S_{xx} : Section modulus of the gross section about the X-X axis (strong axis).
 R_x : Radius of gyration of the gross section about the X-X axis (strong axis).
 I_{yy} : Moment of inertia of the gross section about the Y-Y (weak axis).
 R_y : Radius of gyration of the gross section about the Y-Y axis (weak axis).

Effective Properties X-X

- I_{xx}** : Effective Moment of inertia for deflection about the X-X axis (strong axis).
 S_{xx} : Effective Section modulus about the X-X axis (strong axis).
 M_{a-L} : Allowable moment at yield, based on local buckling.
 M_{a-D} : Allowable moment based on distortional buckling (AISI S100 F4 and Appendix 2.3.4.3).
 V_{ag} : Allowable strong axis shear away from punchouts, per AISI S100 G2.1
 V_{aNet} : Allowable strong axis shear at a punchout, per AISI S100 G3

Torsional Properties

- J** : St. Venant torsional constant.
 C_w : Torsional warping constant.
 X_o : Distance from shear center to the centroid along the principal X-axis.
 m : Distance from shear center to the mid-plane of the web.
 R_o : Polar radius of gyration about the centroidal principal axis.
 β : $1 - (X_o/R_o)^2$
 L_u : The longest weak axis (L_y) and torsional (L_t) unbraced length at which lateral-torsional buckling need not be considered for flexure in accordance with AISI S100 (Commentary F2.1).

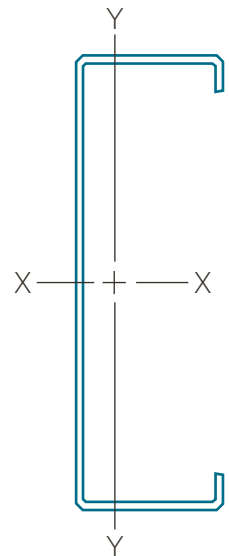

Section Properties

Section Properties • Standard Non-Equivalent Products • Drywall Framing Stud

Section	Design Thickness (in)	F _y (ksi)	Area (in ²)	Weight (lb/ft)	Gross Properties					Effective Properties					Torsional Properties						L _u (in)	
					I _{xx} (in ⁴)	S _{xx} (in ³)	R _x (in)	I _{yy} (in ⁴)	R _y (in)	I _{xx} (in ⁴)	S _{xx} (in ³)	M _{e-L} (in-k)	M _{ed} (in-k)	V _{ag} (lb)	V _{net} (lb)	Jx1000 (in ⁴)	C _w (in ⁶)	X _o (in)	m (in)	R _o (in)		β
162S125-18	0.0188	33	0.080	0.27	0.038	0.046	0.686	0.016	0.447	0.034	0.031	0.61	0.59	302	100	0.009	0.009	-1.029	0.594	1.315	0.388	29.0
162S125-27	0.0283	33	0.120	0.41	0.056	0.069	0.682	0.023	0.443	0.055	0.053	1.05	1.05	494	106	0.032	0.013	-1.018	0.587	1.303	0.390	29.1
162S125-30	0.0312	33	0.132	0.45	0.061	0.075	0.681	0.026	0.441	0.060	0.060	1.19	1.27	543	106	0.043	0.014	-1.014	0.585	1.299	0.390	29.2
162S125-33	0.0346	33	0.145	0.49	0.067	0.083	0.679	0.028	0.440	0.066	0.069	1.37	1.46	601	105	0.058	0.016	-1.010	0.583	1.294	0.391	29.3
250S125-18	0.0188	33	0.097	0.33	0.099	0.079	1.014	0.019	0.439	0.089	0.060	1.18	0.93	258	196	0.011	0.023	-0.904	0.543	1.428	0.599	29.0
250S125-27	0.0283	33	0.144	0.49	0.147	0.118	1.009	0.027	0.434	0.145	0.098	1.93	1.68	685	344	0.039	0.034	-0.893	0.537	1.416	0.602	28.9
250S125-30	0.0312	33	0.159	0.54	0.161	0.129	1.008	0.030	0.433	0.159	0.110	2.18	1.92	832	378	0.052	0.037	-0.890	0.535	1.413	0.603	28.9
250S125-33	0.0346	33	0.176	0.60	0.178	0.142	1.007	0.033	0.431	0.175	0.126	2.48	2.23	975	399	0.070	0.040	-0.886	0.532	1.409	0.604	28.9
350S125-18	0.0188	33	0.115	0.39	0.215	0.123	1.366	0.021	0.423	0.197	0.072	1.42	1.33	180	159	0.014	0.050	-0.798	0.495	1.638	0.763	28.8
350S125-27	0.0283	33	0.173	0.59	0.320	0.183	1.361	0.030	0.419	0.313	0.130	2.57	2.43	614	359	0.046	0.073	-0.788	0.489	1.627	0.766	28.7
350S125-30	0.0312	33	0.190	0.65	0.351	0.201	1.360	0.033	0.417	0.346	0.150	2.97	2.80	824	436	0.062	0.079	-0.784	0.488	1.624	0.767	28.6
350S125-33	0.0346	33	0.210	0.72	0.388	0.222	1.358	0.036	0.416	0.382	0.175	3.46	3.25	1024	487	0.084	0.087	-0.781	0.485	1.621	0.768	28.6
362S125-18	0.0188	33	0.118	0.40	0.234	0.129	1.409	0.021	0.421	0.215	0.075	1.48	1.38	173	163	0.014	0.054	-0.786	0.490	1.667	0.778	28.8
362S125-27	0.0283	33	0.176	0.60	0.347	0.192	1.404	0.031	0.416	0.340	0.135	2.67	2.52	592	370	0.047	0.079	-0.776	0.484	1.657	0.781	28.6
362S125-30	0.0312	33	0.194	0.66	0.381	0.210	1.402	0.033	0.415	0.375	0.156	3.09	2.91	794	449	0.063	0.086	-0.773	0.482	1.654	0.782	28.6
362S125-33	0.0346	33	0.215	0.73	0.421	0.232	1.401	0.037	0.413	0.415	0.182	3.60	3.39	1024	521	0.086	0.094	-0.770	0.480	1.651	0.783	28.5
400S125-18 ¹	0.0188	33	0.125	0.42	0.294	0.147	1.536	0.021	0.415	0.273	0.083	1.64	1.53	156	156	0.015	0.068	-0.755	0.475	1.761	0.816	28.7
400S125-27	0.0283	33	0.187	0.64	0.438	0.219	1.531	0.031	0.410	0.428	0.151	2.98	2.81	533	398	0.050	0.098	-0.745	0.469	1.751	0.819	28.5
400S125-30	0.0312	33	0.206	0.70	0.481	0.240	1.529	0.034	0.409	0.473	0.174	3.44	3.25	715	484	0.067	0.108	-0.742	0.467	1.748	0.820	28.5
400S125-33	0.0346	33	0.228	0.77	0.531	0.265	1.527	0.038	0.407	0.523	0.203	4.02	3.78	976	595	0.091	0.118	-0.738	0.465	1.745	0.821	28.4
550S125-18 ²	0.0188	33	0.153	0.52	0.630	0.229	2.029	0.023	0.390	0.534	0.132	2.61	2.12	112	112	0.018	0.141	-0.651	0.423	2.166	0.910	28.2
550S125-27	0.0283	33	0.229	0.78	0.939	0.341	2.023	0.034	0.385	0.898	0.246	4.87	3.92	382	382	0.061	0.205	-0.642	0.417	2.158	0.912	27.9
550S125-30	0.0312	33	0.252	0.86	1.032	0.375	2.022	0.037	0.384	0.996	0.286	5.65	4.55	512	512	0.082	0.224	-0.639	0.416	2.155	0.912	27.9
550S125-33	0.0346	33	0.279	0.95	1.140	0.415	2.020	0.041	0.382	1.112	0.335	6.63	5.33	699	699	0.112	0.246	-0.636	0.414	2.152	0.913	27.8
600S125-18 ²	0.0188	33	0.162	0.55	0.779	0.260	2.190	0.024	0.382	0.648	0.145	2.86	2.27	102	102	0.019	0.172	-0.623	0.408	2.308	0.927	28.0
600S125-27 ¹	0.0283	33	0.243	0.83	1.161	0.387	2.184	0.035	0.378	1.097	0.271	5.35	4.27	349	349	0.065	0.251	-0.614	0.403	2.300	0.929	27.7
600S125-30	0.0312	33	0.268	0.91	1.276	0.425	2.182	0.038	0.376	1.219	0.315	6.22	4.96	468	468	0.087	0.274	-0.611	0.401	2.297	0.929	27.7
600S125-33	0.0346	33	0.297	1.01	1.410	0.470	2.180	0.042	0.375	1.361	0.370	7.31	5.82	638	638	0.118	0.300	-0.608	0.399	2.294	0.930	27.6

Notes:

1. Calculated properties are based on AISI S100-16 "North American Specification for the Design of Cold-Formed Steel Structural Members".
2. Effective properties incorporate the strength increase from the cold work of forming as applicable per AISI A3.3.2.
3. Tabulated gross properties, including torsional properties, are based upon full-unreduced cross section of the studs, away from punchouts.
4. For deflection calculations, use the effective moment of inertia.

¹Web-height to thickness ratio exceeds 200. Web stiffeners are required at all support points and concentrated loads.

Section Properties • Standard Non-Equivalent Products • Drywall Framing Track

Section	Design Thickness (in)	F _y (ksi)	Gross Properties							Effective Properties				Torsional Properties					
			Area (in ²)	Weight (lb/ft)	I _{xx} (in ⁴)	S _{xx} (in ³)	R _x (in)	I _{yy} (in ⁴)	R _y (in)	I _{xx} (in ⁴)	S _{xx} (in ³)	M _{e-L} (in-k)	V _{eg} (lb)	Jx1000 (in ⁴)	C _w (in ⁶)	X _c (in)	m (in)	R _o (in)	β
162T 125-18	0.0188	33	0.078	0.26	0.042	0.048	0.733	0.013	0.411	0.030	0.025	0.50	302	0.0091	0.007	-0.876	0.503	1.215	0.479
162T 125-27	0.0283	33	0.117	0.40	0.063	0.072	0.735	0.020	0.410	0.051	0.044	0.87	541	0.0312	0.010	-0.872	0.501	1.211	0.482
162T 125-30	0.0312	33	0.129	0.44	0.070	0.079	0.735	0.022	0.409	0.057	0.050	1.00	597	0.0417	0.012	-0.870	0.500	1.210	0.483
162T 125-33	0.0346	33	0.143	0.49	0.077	0.087	0.736	0.024	0.408	0.066	0.058	1.15	663	0.0569	0.013	-0.868	0.499	1.209	0.484
250T 125-18	0.0188	33	0.094	0.32	0.104	0.079	1.052	0.015	0.400	0.078	0.044	0.88	245	0.0111	0.018	-0.767	0.460	1.362	0.682
250T 125-27	0.0283	33	0.141	0.48	0.157	0.119	1.053	0.022	0.398	0.129	0.079	1.56	685	0.0378	0.027	-0.763	0.457	1.360	0.685
250T 125-30	0.0312	33	0.156	0.53	0.173	0.131	1.053	0.025	0.397	0.145	0.090	1.77	832	0.0506	0.030	-0.762	0.456	1.359	0.686
250T 125-33	0.0346	33	0.173	0.59	0.192	0.145	1.054	0.027	0.397	0.166	0.103	2.03	1024	0.0690	0.033	-0.760	0.456	1.358	0.687
250T 150-27	0.0283	33	0.156	0.53	0.181	0.137	1.078	0.037	0.486	0.139	0.082	1.61	685	0.0415	0.044	-0.976	0.575	1.534	0.595
250T 150-30	0.0312	33	0.172	0.58	0.200	0.151	1.078	0.040	0.486	0.157	0.093	1.83	832	0.0557	0.049	-0.975	0.574	1.533	0.595
250T 150-33	0.0346	33	0.190	0.65	0.221	0.167	1.079	0.045	0.485	0.180	0.107	2.11	1024	0.0759	0.054	-0.973	0.573	1.532	0.596
250T 200-33	0.0346	33	0.225	0.76	0.280	0.212	1.117	0.097	0.658	0.203	0.112	2.22	1024	0.0897	0.118	-1.418	0.813	1.922	0.455
350T 125-18	0.0188	33	0.113	0.38	0.220	0.121	1.395	0.017	0.382	0.174	0.062	1.22	173	0.0133	0.038	-0.675	0.418	1.596	0.821
350T 125-27	0.0283	33	0.170	0.58	0.331	0.182	1.396	0.025	0.381	0.277	0.128	2.53	590	0.0453	0.057	-0.670	0.416	1.595	0.823
350T 125-30	0.0312	33	0.187	0.64	0.365	0.200	1.396	0.027	0.380	0.312	0.145	2.86	790	0.0607	0.063	-0.669	0.415	1.594	0.824
350T 125-33	0.0346	33	0.207	0.71	0.405	0.222	1.397	0.030	0.379	0.355	0.165	3.27	1024	0.0828	0.070	-0.668	0.414	1.594	0.824
350T 150-27	0.0283	33	0.184	0.63	0.377	0.207	1.432	0.041	0.470	0.298	0.132	2.62	590	0.0491	0.094	-0.869	0.529	1.739	0.751
350T 150-30	0.0312	33	0.203	0.69	0.416	0.228	1.432	0.045	0.470	0.336	0.150	2.96	790	0.0658	0.103	-0.867	0.528	1.739	0.751
350T 150-33	0.0346	33	0.225	0.76	0.461	0.253	1.432	0.049	0.469	0.382	0.171	3.39	1024	0.0897	0.114	-0.866	0.527	1.738	0.752
350T 200-33	0.0346	33	0.259	0.88	0.574	0.315	1.488	0.108	0.646	0.428	0.181	3.57	1024	0.1035	0.249	-1.285	0.761	2.069	0.614
362T 125-18	0.0188	33	0.115	0.39	0.238	0.127	1.437	0.017	0.380	0.189	0.064	1.26	167	0.0136	0.042	-0.665	0.413	1.628	0.833
362T 125-27	0.0283	33	0.173	0.59	0.358	0.191	1.438	0.025	0.378	0.301	0.135	2.66	569	0.0463	0.062	-0.661	0.411	1.627	0.835
362T 125-30	0.0312	33	0.191	0.65	0.395	0.210	1.438	0.027	0.378	0.339	0.152	3.01	762	0.0620	0.068	-0.659	0.410	1.627	0.836
362T 125-33	0.0346	33	0.212	0.72	0.438	0.232	1.439	0.030	0.377	0.385	0.174	3.44	1024	0.0845	0.076	-0.658	0.410	1.626	0.836
362T 150-27	0.0283	33	0.187	0.64	0.408	0.217	1.475	0.041	0.468	0.323	0.140	2.76	569	0.0500	0.102	-0.857	0.524	1.769	0.765
362T 150-30	0.0312	33	0.207	0.70	0.450	0.239	1.475	0.045	0.467	0.364	0.158	3.12	762	0.0670	0.112	-0.856	0.523	1.768	0.766
362T 150-33	0.0346	33	0.229	0.78	0.499	0.264	1.475	0.050	0.467	0.414	0.180	3.56	1024	0.0914	0.124	-0.854	0.522	1.768	0.766
362T 200-33	0.0346	33	0.264	0.90	0.619	0.329	1.533	0.110	0.645	0.464	0.190	3.76	1024	0.1052	0.269	-1.270	0.754	2.092	0.631
400T 125-18 ¹	0.0188	33	0.122	0.42	0.298	0.145	1.562	0.017	0.374	0.241	0.070	1.39	151	0.0144	0.052	-0.637	0.400	1.727	0.864
400T 125-27	0.0283	33	0.184	0.63	0.449	0.217	1.562	0.025	0.372	0.380	0.156	3.08	515	0.0491	0.078	-0.633	0.398	1.726	0.866
400T 125-30	0.0312	33	0.203	0.69	0.495	0.239	1.563	0.028	0.371	0.427	0.176	3.49	689	0.0658	0.085	-0.632	0.397	1.726	0.866
400T 125-33	0.0346	33	0.225	0.76	0.549	0.265	1.563	0.031	0.371	0.484	0.201	3.97	940	0.0897	0.095	-0.630	0.396	1.725	0.867
400T 150-27	0.0283	33	0.198	0.67	0.509	0.246	1.602	0.042	0.461	0.409	0.154	3.04	515	0.0529	0.127	-0.824	0.509	1.860	0.804
400T 150-30	0.0312	33	0.218	0.74	0.561	0.271	1.603	0.046	0.461	0.458	0.183	3.61	689	0.0708	0.140	-0.823	0.508	1.860	0.804
400T 150-33	0.0346	33	0.242	0.82	0.622	0.300	1.603	0.051	0.460	0.519	0.208	4.12	940	0.0966	0.155	-0.821	0.507	1.859	0.805
400T 200-33	0.0346	33	0.277	0.94	0.768	0.371	1.666	0.113	0.639	0.581	0.220	4.34	940	0.1104	0.336	-1.229	0.737	2.167	0.678
550T 125-27	0.0283	33	0.226	0.77	0.948	0.336	2.046	0.027	0.348	0.786	0.192	3.79	372	0.0604	0.160	-0.543	0.352	2.146	0.936
550T 125-30	0.0312	33	0.250	0.85	1.045	0.371	2.047	0.030	0.347	0.897	0.226	4.47	499	0.0810	0.176	-0.542	0.351	2.145	0.936
550T 125-33	0.0346	33	0.277	0.94	1.159	0.411	2.047	0.033	0.346	1.029	0.270	5.33	680	0.1104	0.195	-0.541	0.350	2.145	0.936
550T 150-27	0.0283	33	0.241	0.82	1.059	0.376	2.099	0.046	0.436	0.893	0.207	4.10	372	0.0642	0.263	-0.716	0.456	2.260	0.900
550T 150-30	0.0312	33	0.265	0.90	1.168	0.414	2.099	0.050	0.435	0.995	0.251	4.96	499	0.0860	0.289	-0.715	0.455	2.259	0.900
550T 150-33	0.0346	33	0.294	1.00	1.295	0.459	2.099	0.055	0.434	1.115	0.310	6.12	680	0.1173	0.320	-0.714	0.455	2.259	0.900
550T 200-33	0.0346	33	0.329	1.12	1.567	0.555	2.184	0.123	0.613	1.246	0.307	6.06	680	0.1311	0.694	-1.088	0.674	2.516	0.813
600T 125-27 ¹	0.0283	33	0.241	0.82	1.169	0.381	2.204	0.028	0.340	0.958	0.211	4.16	341	0.0642	0.196	-0.519	0.339	2.290	0.949
600T 125-30	0.0312	33	0.265	0.90	1.288	0.420	2.204	0.031	0.340	1.095	0.249	4.92	456	0.0860	0.215	-0.518	0.338	2.290	0.949
600T 125-33	0.0346	33	0.294	1.00	1.429	0.465	2.205	0.034	0.339	1.258	0.297	5.87	622	0.1173	0.238	-0.516	0.337	2.289	0.949
600T 150-27 ¹	0.0283	33	0.255	0.87	1.301	0.424	2.260	0.047	0.427	1.012	0.214	4.23	341	0.0680	0.320	-0.686	0.441	2.400	0.918
600T 150-30	0.0312	33	0.281	0.96	1.434	0.467	2.260	0.051	0.427	1.159	0.253	5.01	456	0.0911	0.352	-0.685	0.440	2.400	0.918
600T 150-33	0.0346	33	0.311	1.06	1.590	0.517	2.260	0.057	0.426	1.335	0.303	5.99	622	0.1242	0.390	-0.684	0.439	2.400	0.919
600T 200-33	0.0346	33	0.346	1.18	1.913	0.623	2.352	0.126	0.604	1.542	0.333	6.59	622	0.1380	0.847	-1.048	0.655	2.645	0.843

Notes:

1. Web-height to thickness ratio exceeds 200. Web stiffeners are required at all support points and concentric loads.
2. When web height thickness ratio exceeds 260, or flange width-to-thickness ratio exceeds 60, effective properties are not calculated (limitations in AISI Section B4.1).

Section Properties

Section Properties • Slotted Deflection Track

Section	Design Thickness (in)	F _y (ksi)	Gross Properties							Effective Properties		
			Area (in ²)	Net Area (in ²)	Weight (lb/ft)	I _{xx} (in ⁴)	R _x (in)	I _{yy} (in ⁴)	R _y (in)	I _{yy} (in ⁴)	S _{yy} (in ³)	M _{sp-y} (in-k)
250SLT250-18	0.0188	33	0.134	0.081	0.457	0.093	0.830	0.175	1.141	0.061	0.035	0.58
250SLT250-30	0.0312	33	0.234	0.140	0.796	0.160	0.828	0.306	1.143	0.116	0.079	1.30
250SLT250-33	0.0346	33	0.259	0.156	0.883	0.178	0.827	0.339	1.144	0.129	0.087	1.43
362SLT250-18	0.0188	33	0.154	0.101	0.526	0.105	0.823	0.382	1.573	0.140	0.053	0.87
362SLT250-30	0.0312	33	0.269	0.175	0.915	0.181	0.820	0.667	1.575	0.281	0.126	2.08
362SLT250-33	0.0346	33	0.298	0.194	1.015	0.200	0.820	0.740	1.575	0.312	0.144	2.38
362SLT300-30	0.0312	33	0.300	0.175	1.022	0.296	0.992	0.776	1.607	0.281	0.126	2.08
362SLT300-33	0.0346	33	0.333	0.194	1.133	0.327	0.992	0.861	1.608	0.312	0.144	2.38
362SLT350-30	0.0312	33	0.331	0.175	1.128	0.447	1.161	0.885	1.634	0.281	0.126	2.08
362SLT350-33	0.0346	33	0.367	0.194	1.250	0.495	1.161	0.981	1.634	0.312	0.144	2.38
400SLT250-18	0.0188	33	0.161	0.107	0.548	0.108	0.818	0.472	1.711	0.174	0.059	0.97
400SLT250-30	0.0312	33	0.281	0.187	0.955	0.187	0.816	0.824	1.713	0.357	0.142	2.34
400SLT250-33	0.0346	33	0.311	0.207	1.059	0.207	0.815	0.914	1.714	0.396	0.162	2.68
400SLT300-30	0.0312	33	0.312	0.187	1.061	0.305	0.989	0.956	1.751	0.357	0.142	2.34
400SLT300-33	0.0346	33	0.346	0.207	1.177	0.338	0.989	1.060	1.751	0.396	0.162	2.68
400SLT350-30	0.0312	33	0.343	0.187	1.168	0.462	1.160	1.088	1.780	0.357	0.142	2.34
400SLT350-33	0.0346	33	0.380	0.207	1.295	0.511	1.159	1.207	1.781	0.396	0.162	2.68
600SLT250-18	0.0188	33	0.197	0.143	0.670	0.122	0.786	1.156	2.422	NA	NA	NA
600SLT250-30	0.0312	33	0.343	0.250	1.168	0.211	0.784	2.016	2.424	0.928	0.224	3.70
600SLT250-33	0.0346	33	0.380	0.277	1.295	0.233	0.783	2.236	2.424	1.051	0.260	4.29
600SLT300-30	0.0312	33	0.374	0.250	1.274	0.347	0.962	2.307	2.482	0.928	0.224	3.70
600SLT300-33	0.0346	33	0.415	0.277	1.412	0.384	0.962	2.559	2.483	1.051	0.260	4.29
600SLT350-30	0.0312	33	0.406	0.250	1.380	0.526	1.139	2.598	2.531	0.928	0.224	3.70
600SLT350-33	0.0346	33	0.450	0.277	1.530	0.583	1.138	2.882	2.532	1.051	0.260	4.29
800SLT250-30	0.0312	33	0.406	0.312	1.380	0.227	0.749	3.894	3.099	1.815	0.307	5.07
800SLT250-33	0.0346	33	0.450	0.346	1.530	0.252	0.748	4.318	3.099	2.072	0.358	5.91
800SLT300-30	0.0312	33	0.437	0.312	1.486	0.376	0.928	4.407	3.176	1.815	0.307	5.07
800SLT300-33	0.0346	33	0.484	0.346	1.648	0.416	0.927	4.887	3.177	2.072	0.358	5.91
800SLT350-30	0.0312	33	0.468	0.312	1.592	0.573	1.107	4.920	3.242	1.815	0.307	5.07
800SLT350-33	0.0346	33	0.519	0.346	1.766	0.635	1.106	5.456	3.243	2.072	0.358	5.91

Notes:

- Gross properties calculated at the gross section, away from slots.
- Web depth taken as nominal depth + (2 x thickness) + inside corner radius.
- Effective properties based on AISI S100-16 and the following: net flange on tension side; effective flange on compression side, ignoring steel below the slot; effective web per S100-16, Appendix 1, Section 1.1.2; $\Omega = 2.0$ per S100-16, Section A1.2 (c).
- Effective properties are not calculated for 6" x 18-mil products (web h/t > 260).

All Products Table Information

Limiting Heights Tables

Which Limiting Heights Table is the Correct Table to Use?

Composite Assemblies

When the gypsum board is installed on both sides of the stud flange for the full height of the wall, it is a composite wall.

Composite

Gypsum board full height on both sides and fastened to all framing members, including top and bottom tracks.

**TOP TRACK MUST BE RIGID,
NOT DEFLECTION TYPE.**

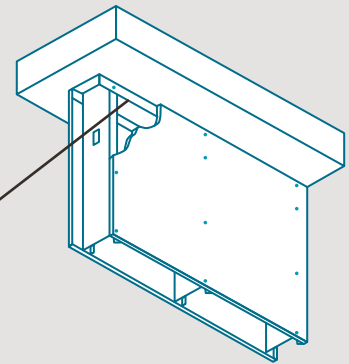

Non-Composite Assemblies

When the gypsum board stops at the ceiling level, but the stud continues to the deck, it is a noncomposite condition.

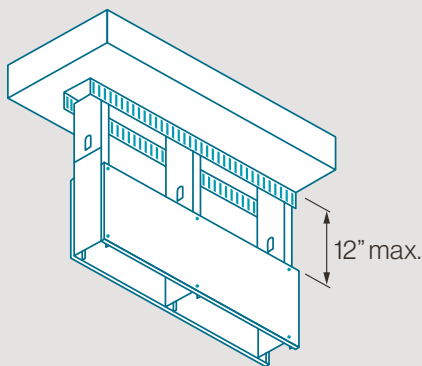

Non-Composite Fully Braced

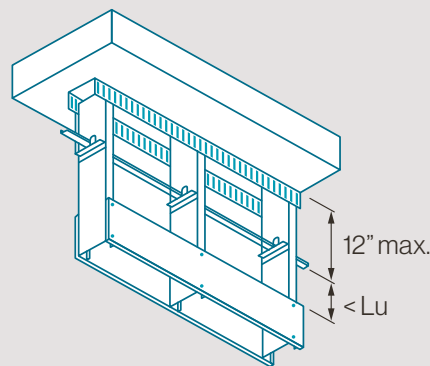

Non-Composite Fully Braced

Bracing spacing above gypsum board is less than Lu

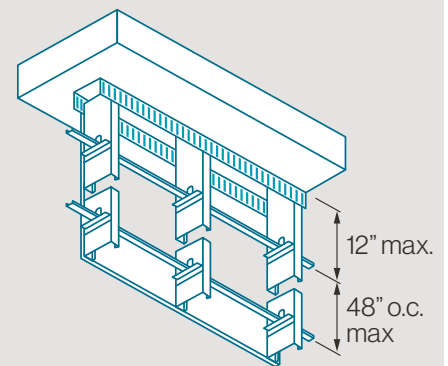

Non-Composite Braced at 48" o.c.

Gypsum board placed on only one side

Distance of unbraced length (Lu) can be found in the Section Properties starting on page 14.

Limiting Wall Heights | Composite

Composite Limiting Heights • Standard Non-Equivalent Products

Member	Spacing o.c. (in)	F _y (ksi)	5 psf			7.5 psf			10 psf			15 psf		
			L/120	L/240	L/360	L/120	L/240	L/360	L/120	L/240	L/360	L/120	L/240	L/360
162S125-18	12	33	13'-0" †	11'-1"	9'-10"	10'-8" †	9'-8"	8'-7"	9'-3" †	8'-9"	7'-9"	---	---	---
	16		11'-3" †	10'-1"	8'-11"	9'-3" †	8'-9"	7'-9"	8'-0" †	7'-11"	---	---	---	---
	24		9'-3" †	8'-9"	7'-9"	---	---	---	---	---	---	---	---	---
162S125-27	12	33	14'-9"	11'-8"	10'-2"	12'-10"	10'-2"	8'-7"	11'-8"	9'-1"	7'-6"	8'-6"	---	---
	16		13'-4"	10'-7"	9'-1"	11'-8"	9'-1"	7'-6"	10'-7"	7'-11"	---	---	---	---
	24		11'-8"	9'-1"	---	10'-2"	---	---	9'-1"	---	---	---	---	---
162S125-30	12	33	14'-11"	11'-10"	10'-4"	13'-1"	10'-4"	8'-11"	11'-10"	9'-4"	7'-11"	9'-10"	7'-11"	---
	16		13'-7"	10'-9"	9'-4"	11'-10"	9'-4"	7'-11"	10'-9"	8'-3"	---	8'-6"	---	---
	24		11'-10"	9'-4"	7'-11"	10'-4"	7'-11"	---	9'-4"	---	---	---	---	---
250S125-18	12	33	16'-4" †	14'-2"	12'-9"	13'-4" †	12'-4"	11'-2"	11'-7" †	11'-3"	10'-2"	---	---	---
	16		14'-2" †	12'-10"	11'-7"	11'-7" †	11'-3"	10'-2"	10'-0" †	10'-0" †	9'-0"	---	---	---
	24		11'-7" †	11'-3"	10'-2"	9'-5" †	9'-5" †	8'-6"	8'-2" †	8'-2" †	---	---	---	---
250S125-27	12	33	18'-7"	15'-4"	13'-9"	16'-3"	13'-5"	11'-12"	14'-9"	12'-2"	10'-11"	10'-6"	10'-6" †	9'-4"
	16		16'-10"	13'-11"	12'-5"	14'-9"	12'-2"	10'-11"	13'-5"	11'-1"	9'-11"	9'-1"	9'-1" †	8'-1"
	24		14'-9"	12'-2"	10'-11"	12'-11"	10'-8"	9'-4"	11'-3" †	9'-8"	8'-1"	---	---	---
250S125-30	12	33	18'-5"	15'-10"	14'-1"	16'-1"	13'-10"	12'-4"	14'-7"	12'-7"	11'-2"	11'-0"	11'-0" †	9'-9"
	16		16'-9"	14'-5"	12'-10"	14'-7"	12'-7"	11'-2"	13'-3"	11'-5"	10'-2"	9'-6"	9'-6" †	8'-8"
	24		14'-7"	12'-7"	11'-2"	12'-9"	11'-0"	9'-9"	11'-7"	10'-0"	8'-8"	7'-9"	7'-9" †	---
250S125-33	12	33	19'-8"	15'-8"	13'-8"	17'-3"	13'-8"	11'-11"	15'-8"	12'-5"	10'-10"	11'-5"	10'-10"	9'-5"
	16		17'-11"	14'-3"	12'-5"	15'-8"	12'-5"	10'-10"	14'-3"	11'-3"	9'-10"	9'-11"	9'-10"	8'-4"
	24		15'-8"	12'-5"	10'-10"	13'-8"	10'-10"	9'-5"	12'-4" †	9'-10"	8'-4"	8'-1"	8'-1" †	---
350S125-18	12	33	18'-3" †	16'-4"	14'-4"	14'-11" †	14'-4"	12'-6"	12'-11" †	12'-11" †	11'-4"	8'-5"	8'-5" †	8'-5" †
	16		15'-10" †	14'-10"	13'-0"	12'-11" †	12'-11" †	11'-4"	11'-2" †	11'-2" †	10'-3"	---	---	---
	24		12'-11" †	12'-11" †	11'-4"	10'-7" †	10'-7" †	9'-11"	9'-2" †	9'-2" †	9'-0"	---	---	---
350S125-27	12	33	22'-6"	17'-11"	15'-7"	19'-8"	15'-7"	13'-8"	17'-11"	14'-2"	12'-4"	12'-0"	12'-0" †	10'-8"
	16		20'-6"	16'-3"	14'-2"	17'-11"	14'-2"	12'-4"	15'-10" †	12'-11"	11'-2"	10'-5"	10'-5" †	---
	24		17'-11"	14'-2"	12'-4"	14'-11" †	12'-4"	10'-8"	12'-11" †	11'-2"	---	---	---	---
350S125-30	12	33	22'-6"	17'-11"	15'-8"	19'-8"	15'-8"	13'-8"	17'-11"	14'-2"	12'-4"	12'-10"	12'-4"	10'-7"
	16		20'-6"	16'-3"	14'-2"	17'-11"	14'-2"	12'-4"	16'-3"	12'-11"	11'-1"	11'-1"	11'-1" †	---
	24		17'-11"	14'-2"	12'-4"	15'-8"	12'-4"	10'-7"	13'-9" †	11'-1"	---	---	---	---
350S125-33	12	33	23'-0"	18'-3"	15'-11"	20'-1"	15'-11"	13'-11"	18'-3"	14'-6"	12'-8"	13'-3"	12'-8"	10'-10"
	16		20'-11"	16'-7"	14'-6"	18'-3"	14'-6"	12'-8"	16'-7"	13'-2"	11'-4"	11'-6"	11'-4"	9'-8"
	24		18'-3"	14'-6"	12'-8"	15'-11"	12'-8"	10'-10"	14'-4" †	11'-4"	9'-8"	---	---	---
362S125-18	12	33	18'-8" †	16'-8"	14'-7"	15'-3" †	14'-7"	12'-9"	13'-2" †	13'-2" †	11'-6"	8'-8"	8'-8" †	8'-8" †
	16		16'-2" †	15'-2"	13'-3"	13'-2" †	13'-2" †	11'-6"	11'-5" †	11'-5" †	10'-4"	---	---	---
	24		13'-2" †	13'-2" †	11'-6"	10'-9" †	10'-9" †	9'-11"	9'-4" †	9'-4" †	8'-11"	---	---	---
362S125-27	12	33	22'-10"	18'-2"	15'-10"	19'-11"	15'-10"	13'-10"	18'-2"	14'-5"	12'-6"	12'-0"	12'-0" †	10'-7"
	16		20'-9"	16'-6"	14'-5"	18'-2"	14'-5"	12'-6"	15'-9" †	13'-1"	12'-2"	10'-5"	10'-5" †	---
	24		18'-2"	14'-5"	12'-6"	14'-11" †	12'-6"	10'-7"	12'-11" †	11'-1"	---	---	---	---
362S125-30	12	33	22'-10"	18'-3"	16'-4"	19'-11"	16'-0"	14'-3"	18'-1"	14'-6"	12'-11"	12'-8"	12'-8" †	10'-11"
	16		20'-8"	16'-7"	14'-10"	18'-1"	14'-6"	12'-11"	16'-5"	13'-2"	11'-6"	11'-0"	11'-0" †	---
	24		18'-1"	14'-6"	12'-11"	15'-9" †	12'-8"	10'-11"	13'-8" †	11'-4"	---	---	---	---
362S125-33	12	33	24'-2"	19'-2"	16'-9"	21'-1"	16'-9"	14'-8"	19'-2"	15'-3"	13'-4"	13'-5"	13'-4"	11'-4"
	16		21'-11"	17'-5"	15'-3"	19'-2"	15'-3"	13'-4"	17'-5"	13'-10"	11'-11"	11'-8"	11'-8" †	10'-1"
	24		19'-2"	15'-3"	13'-4"	16'-8" †	13'-4"	11'-4"	14'-5" †	11'-11"	10'-1"	---	---	---

Composite Limiting Heights • Standard Non-Equivalent Products

Member	Spacing o.c. (in)	F _y (ksi)	5 psf			7.5 psf			10 psf			15 psf		
			L/120	L/240	L/360	L/120	L/240	L/360	L/120	L/240	L/360	L/120	L/240	L/360
400S125-18	12	33	19'-3" †	17'-6"	15'-4"	15'-9" †	15'-4"	13'-4"	13'-8" †	13'-8" †	12'-2"	8'-11"	8'-11" †	8'-11" †
	16		16'-8" †	15'-11"	13'-11"	13'-8" †	13'-8" †	12'-2"	11'-10" †	11'-10" †	11'-0"	7'-9"	7'-9" †	7'-9" †
	24		13'-8" †	13'-8" †	12'-2"	11'-2" †	11'-2" †	10'-7"	9'-8" †	9'-8" †	9'-7"	---	---	---
400S125-27	12	33	24'-6"	19'-5"	17'-0"	21'-5"	17'-0"	14'-10"	18'-8" †	15'-5"	13'-6"	12'-3"	12'-3" †	11'-8"
	16		22'-3"	17'-8"	15'-5"	18'-8" †	15'-5"	13'-6"	16'-2" †	14'-0"	12'-2"	10'-8"	10'-8" †	10'-6"
	24		18'-8" †	15'-5"	13'-6"	15'-3" †	13'-6"	11'-8"	13'-3" †	12'-2"	10'-6"	---	---	---
400S125-30	12	33	24'-6"	19'-5"	17'-0"	21'-5"	17'-0"	14'-10"	19'-5"	15'-5"	13'-6"	13'-2"	13'-2"	11'-7"
	16		22'-3"	17'-8"	15'-5"	19'-5"	15'-5"	13'-6"	17'-5"	14'-0"	12'-2"	11'-5"	11'-5"	10'-4"
	24		19'-5"	15'-5"	13'-6"	16'-5"	13'-6"	11'-7"	14'-2"	12'-2"	10'-4"	---	---	---
400S125-33	12	33	25'-3"	20'-1"	17'-6"	22'-1"	17'-6"	20'-1"	20'-1"	15'-11"	13'-11"	13'-11"	13'-11"	12'-0"
	16		22'-11"	18'-3"	15'-11"	20'-1"	15'-11"	18'-3"	18'-3"	14'-5"	12'-7"	12'-1"	12'-1"	10'-9"
	24		20'-1"	15'-11"	13'-11"	17'-3"	13'-11"	15'-0"	15'-0"	12'-7"	10'-9"	9'-10"	9'-10"	---
550S125-18	12	33	21'-11"	21'-11"	21'-10"	17'-10"	17'-10"	17'-0"	15'-6"	15'-6"	15'-6"	---	---	---
	16		14'-6"	19'-0"	17'-9"	15'-6"	15'-6"	15'-6"	13'-5"	13'-5"	13'-5"	---	---	---
	24		11'-10"	15'-6"	15'-6"	12'-8"	12'-8"	12'-8"	---	---	---	---	---	---
550S125-27	12	33	30'-4"	24'-8"	21'-10"	26'-9"	21'-10"	19'-4"	23'-2"	20'-0"	17'-8"	---	---	---
	16		27'-11"	22'-8"	20'-0"	23'-2"	20'-0"	17'-8"	20'-1"	18'-4"	16'-0"	---	---	---
	24		23'-2"	20'-0"	17'-8"	18'-11"	17'-8"	15'-5"	16'-5"	16'-0"	---	---	---	---
550S125-30	12	33	30'-5"	24'-10"	22'-0"	27'-0"	22'-0"	19'-5"	24'-10"	20'-2"	17'-10"	16'-4"	16'-4"	15'-7"
	16		28'-0"	22'-9"	20'-2"	24'-10"	20'-2"	17'-10"	21'-7"	18'-6"	16'-2"	---	---	---
	24		24'-10"	20'-2"	17'-10"	20'-4"	17'-10"	15'-7"	17'-7"	16'-2"	---	---	---	---
600S125-18	12	33	23'-2"	22'-9"	19'-11"	18'-11"	18'-11"	17'-5"	16'-4"	16'-4"	15'-10"	---	---	---
	16		20'-1"	20'-1"	18'-1"	16'-4"	16'-4"	15'-10"	14'-2"	14'-2"	14'-2"	---	---	---
	24		16'-4"	16'-4"	15'-10"	13'-4"	13'-4"	13'-4"	---	---	---	---	---	---
600S125-27	12	33	32'-5"	26'-9"	23'-5"	26'-5"	23'-5"	20'-5"	22'-11"	21'-3"	16'-10"	---	---	---
	16		28'-1"	24'-4"	21'-3"	22'-11"	21'-3"	18'-7"	19'-10"	19'-4"	14'-7"	---	---	---
	24		22'-11"	21'-3"	18'-7"	18'-8"	18'-7"	16'-1"	16'-2"	16'-2"	---	---	---	---
600S125-30	12	33	34'-2"	27'-1"	23'-8"	28'-11"	23'-8"	20'-8"	25'-0"	21'-6"	18'-9"	16'-5"	16'-5"	16'-5"
	16		30'-8"	24'-7"	21'-6"	25'-0"	21'-6"	18'-9"	21'-8"	19'-6"	17'-1"	---	---	---
	24		25'-0"	21'-6"	18'-9"	20'-5"	18'-9"	16'-5"	17'-8"	17'-1"	---	---	---	---
600S125-33	12	33	35'-4"	28'-1"	24'-6"	30'-10"	24'-6"	21'-5"	27'-10"	22'-3"	19'-5"	18'-4"	18'-4"	16'-11"
	16		32'-1"	25'-6"	22'-3"	27'-10"	22'-3"	19'-5"	24'-1"	20'-3"	17'-8"	15'-10"	15'-10"	---
	24		27'-10"	22'-3"	19'-5"	22'-9"	19'-5"	16'-11"	19'-8"	17'-8"	---	---	---	---

Notes:

1. Allowable composite limiting heights are calculated using ICC-ES AC86-2012.
2. Minimum safety factor for strength = 1.508 for 5 to 10 psf, and 2.327 for 15 psf.
3. The gypsum board must be applied full height to each stud flange and installed using minimum No. 6 Type S Drywall screws spaced a maximum of 12 in. on-center for studs at 24-in spacing, and 16 in. on-center for studs at 16 and 12 in. spacing.
4. No fasteners are required for attaching the stud to the track.
5. Stud end bearing must be a minimum of 1 inch.
6. Minimum material yield strength equals 33 ksi.
7. † adjacent to the height value indicates that flexural stress controls the allowable wall height.

Limiting Wall Heights | Non-Composite

Non-Composite Limiting Heights • Standard Non-Equivalent Products

Member	Spacing o.c. (in)	F _y (ksi)	5 psf			7.5 psf			10 psf		
			L/120	L/240	L/360	L/120	L/240	L/360	L/120	L/240	L/360
162S125-18	12	33	8'-10"	7'-7"	6'-7"	7'-3"	6'-7"	5'-9"	6'-3"	6'-0"	5'-3"
	16		7'-8"	6'-11"	6'-0"	6'-3"	6'-0"	5'-3"	5'-5"	5'-5"	4'-9"
	24		6'-3"	6'-0"	5'-3"	5'-1"	5'-1"	4'-7"	4'-5"	4'-5"	4'-2"
162S125-27	12	33	11'-3"	8'-11"	7'-9"	9'-7"	7'-9"	6'-10"	8'-4"	7'-1"	6'-2"
	16		10'-2"	8'-1"	7'-1"	8'-4"	7'-1"	6'-2"	7'-2"	6'-5"	5'-7"
	24		8'-4"	7'-1"	6'-2"	6'-9"	6'-2"	5'-5"	5'-10"	5'-7"	4'-11"
162S125-30	12	33	11'-7"	9'-2"	8'-0"	10'-1"	8'-0"	7'-0"	8'-10"	7'-3"	6'-4"
	16		10'-6"	8'-4"	7'-3"	8'-10"	7'-3"	6'-4"	7'-8"	6'-7"	5'-9"
	24		8'-10"	7'-3"	6'-4"	7'-3"	6'-4"	5'-7"	6'-3"	5'-9"	5'-0"
162S125-33	12	33	12'-0"	9'-6"	8'-3"	10'-5"	8'-3"	7'-3"	9'-6"	7'-6"	6'-7"
	16		10'-10"	8'-7"	7'-6"	9'-6"	7'-6"	6'-7"	8'-3"	6'-10"	6'-0"
	24		9'-6"	7'-6"	6'-7"	7'-9"	6'-7"	5'-9"	6'-9"	6'-0"	5'-2"
250S125-18	12	33	11'-1"	10'-6"	9'-2"	9'-1"	9'-1"	8'-0"	7'-10"	7'-10"	7'-3"
	16		9'-7"	9'-6"	8'-4"	7'-10"	7'-10"	7'-3"	6'-9"	6'-9"	6'-7"
	24		7'-10"	7'-10"	7'-3"	6'-5"	6'-5"	6'-4"	5'-6"	5'-6"	5'-6"
250S125-27	12	33	14'-11"	12'-4"	10'-9"	12'-2"	10'-9"	9'-5"	10'-6"	9'-9"	8'-6"
	16		12'-11"	11'-2"	9'-9"	10'-6"	9'-9"	8'-6"	9'-1"	8'-11"	7'-9"
	24		10'-6"	9'-9"	8'-6"	8'-7"	8'-6"	7'-5"	7'-5"	7'-5"	6'-9"
250S125-30	12	33	16'-0"	12'-9"	11'-1"	13'-0"	11'-1"	9'-8"	12'-2"	10'-1"	8'-10"
	16		13'-10"	11'-7"	10'-1"	11'-3"	10'-1"	8'-10"	10'-6"	9'-2"	8'-0"
	24		11'-3"	10'-1"	8'-10"	9'-2"	8'-10"	7'-8"	8'-7"	8'-0"	7'-0"
250S125-33	12	33	16'-7"	13'-2"	11'-6"	14'-0"	11'-6"	10'-0"	13'-2"	10'-5"	9'-1"
	16		14'-11"	11'-11"	10'-5"	12'-2"	10'-5"	9'-1"	11'-11"	9'-6"	8'-3"
	24		12'-2"	10'-5"	9'-1"	9'-11"	9'-1"	7'-11"	10'-4"	8'-3"	7'-3"
350S125-18	12	33	13'-4"	13'-4"	11'-11"	10'-10"	10'-10"	10'-5"	9'-5"	9'-5"	9'-5"
	16		11'-6"	11'-6"	10'-10"	9'-5"	9'-5"	9'-5"	8'-1"	8'-1"	8'-1"
	24		9'-5"	9'-5"	9'-5"	7'-8"	7'-8"	7'-8"	6'-8"	6'-8"	6'-8"
350S125-27	12	33	17'-11"	16'-0"	13'-11"	14'-8"	13'-11"	12'-2"	12'-8"	12'-8"	11'-1"
	16		15'-7"	14'-6"	12'-8"	12'-8"	12'-8"	11'-1"	11'-0"	11'-0"	10'-1"
	24		12'-8"	12'-8"	11'-1"	10'-4"	10'-4"	9'-8"	8'-11"	8'-11"	8'-9"
350S125-30	12	33	19'-3"	16'-6"	14'-5"	15'-9"	14'-5"	12'-7"	13'-7"	13'-1"	11'-5"
	16		16'-8"	15'-0"	13'-1"	13'-7"	13'-1"	11'-5"	11'-10"	11'-11"	10'-5"
	24		13'-7"	13'-1"	11'-5"	11'-1"	11'-1"	10'-0"	9'-7"	9'-7"	9'-1"
350S125-33	12	33	21'-6"	17'-1"	14'-11"	18'-9"	14'-11"	13'-0"	17'-1"	13'-6"	11'-10"
	16		19'-6"	15'-6"	13'-6"	17'-1"	13'-6"	11'-10"	15'-5"	12'-4"	10'-9"
	24		17'-1"	13'-6"	11'-10"	14'-6"	11'-10"	10'-4"	12'-7"	10'-9"	9'-4"
362S125-18	12	33	13'-6"	13'-6"	12'-4"	11'-1"	11'-1"	10'-9"	9'-7"	9'-7"	9'-7"
	16		11'-9"	11'-9"	11'-2"	9'-7"	9'-7"	9'-7"	8'-3"	8'-3"	8'-3"
	24		9'-7"	9'-7"	9'-7"	7'-10"	7'-10"	7'-10"	6'-9"	6'-9"	6'-9"
362S125-27	12	33	18'-4"	16'-5"	14'-4"	14'-11"	14'-4"	12'-6"	12'-11"	12'-11"	11'-4"
	16		15'-10"	14'-11"	13'-0"	12'-11"	12'-11"	11'-4"	11'-2"	11'-2"	10'-4"
	24		12'-11"	12'-11"	11'-4"	10'-7"	10'-7"	9'-11"	9'-2"	9'-2"	9'-0"
362S125-30	12	33	19'-8"	17'-0"	14'-10"	16'-1"	14'-10"	12'-11"	13'-11"	13'-5"	11'-9"
	16		17'-0"	15'-5"	13'-5"	13'-11"	13'-5"	11'-9"	12'-0"	12'-0"	10'-8"
	24		13'-11"	13'-5"	11'-9"	11'-4"	11'-4"	10'-3"	9'-10"	9'-10"	9'-4"

Non-Composite Limiting Heights • Standard Non-Equivalent Products

Member	Spacing o.c. (in)	F _y (ksi)	5 psf			7.5 psf			10 psf		
			L/120	L/240	L/360	L/120	L/240	L/360	L/120	L/240	L/360
362S125-33	12	33	21'-2"	17'-6"	15'-4"	17'-4"	15'-4"	13'-5"	15'-0"	13'-11"	12'-2"
	16		18'-4"	15'-11"	13'-11"	15'-0"	13'-11"	12'-2"	13'-0"	12'-8"	11'-0"
	24		15'-0"	13'-11"	12'-2"	12'-3"	12'-2"	10'-7"	10'-7"	10'-7"	9'-8"
400S125-18 ¹	12	33	14'-3"	14'-3"	13'-4"	11'-8"	11'-8"	11'-8"	10'-1"	10'-1"	10'-1"
	16		12'-4"	12'-4"	12'-1"	10'-1"	10'-1"	10'-1"	8'-9"	8'-9"	8'-9"
	24		10'-1"	10'-1"	10'-1"	8'-3"	8'-3"	8'-3"	7'-1"	7'-1"	7'-1"
400S125-27	12	33	19'-4"	17'-9"	15'-6"	15'-9"	15'-6"	13'-6"	13'-8"	13'-8"	12'-3"
	16		16'-9"	16'-1"	14'-1"	13'-8"	13'-8"	12'-3"	11'-10"	11'-10"	11'-2"
	24		13'-8"	13'-8"	12'-3"	11'-2"	11'-2"	10'-9"	9'-8"	9'-8"	9'-8"
400S125-30	12	33	20'-9"	18'-4"	16'-0"	16'-11"	16'-0"	14'-0"	14'-8"	14'-7"	12'-8"
	16		18'-0"	16'-8"	14'-7"	14'-8"	14'-7"	12'-8"	12'-8"	12'-8"	11'-6"
	24		14'-8"	14'-7"	12'-8"	12'-0"	12'-0"	11'-1"	10'-4"	10'-4"	10'-1"
400S125-33	12	33	22'-5"	18'-11"	16'-7"	18'-3"	16'-7"	14'-5"	15'-10"	15'-0"	13'-2"
	16		19'-5"	17'-3"	15'-0"	15'-10"	15'-0"	13'-2"	13'-8"	13'-8"	11'-11"
	24		15'-10"	15'-0"	13'-2"	12'-11"	12'-11"	11'-6"	11'-2"	11'-2"	10'-5"
550S125-18 ²	12	33	16'-9"	16'-9"	16'-8"	13'-8"	13'-8"	13'-8"	11'-10"	11'-10"	11'-10"
	16		14'-6"	14'-6"	14'-6"	11'-10"	11'-10"	11'-10"	10'-3"	10'-3"	10'-3"
	24		11'-10"	11'-10"	11'-10"	9'-8"	9'-8"	9'-8"	8'-4"	8'-4"	8'-4"
550S125-27	12	33	22'-10"	22'-9"	19'-10"	18'-8"	18'-8"	17'-4"	16'-2"	16'-2"	15'-9"
	16		19'-9"	19'-9"	18'-0"	16'-2"	16'-2"	15'-9"	14'-0"	14'-0"	14'-0"
	24		16'-2"	16'-2"	15'-9"	13'-2"	13'-2"	13'-2"	11'-5"	11'-5"	11'-5"
550S125-30	12	33	24'-7"	23'-6"	20'-6"	20'-1"	20'-1"	17'-11"	17'-5"	17'-5"	16'-3"
	16		21'-4"	21'-4"	18'-8"	17'-5"	17'-5"	16'-3"	15'-1"	15'-1"	14'-10"
	24		17'-5"	17'-5"	16'-3"	14'-2"	14'-2"	14'-2"	12'-3"	12'-3"	12'-3"
550S125-33	12	33	26'-8"	24'-5"	21'-4"	21'-9"	21'-4"	18'-7"	18'-10"	18'-10"	16'-11"
	16		23'-1"	22'-2"	19'-4"	18'-10"	18'-10"	16'-11"	16'-3"	16'-3"	15'-4"
	24		18'-10"	18'-10"	16'-11"	15'-4"	15'-4"	14'-9"	13'-4"	13'-4"	13'-4"
600S125-18 ²	12	33	17'-4"	17'-4"	17'-4"	14'-2"	14'-2"	14'-2"	12'-3"	12'-3"	12'-3"
	16		15'-0"	15'-0"	15'-0"	12'-3"	12'-3"	12'-3"	10'-7"	10'-7"	10'-7"
	24		12'-3"	12'-3"	12'-3"	10'-0"	10'-0"	10'-0"	8'-8"	8'-8"	8'-8"
600S125-27 ¹	12	33	23'-10"	23'-10"	21'-2"	19'-5"	19'-5"	18'-6"	16'-10"	16'-10"	16'-10"
	16		20'-7"	20'-7"	19'-3"	16'-10"	16'-10"	16'-10"	14'-7"	14'-7"	14'-7"
	24		16'-10"	16'-10"	16'-10"	13'-9"	13'-9"	13'-9"	11'-11"	11'-11"	11'-11"
600S125-30	12	33	25'-8"	25'-2"	22'-0"	21'-0"	21'-0"	19'-2"	18'-2"	18'-2"	17'-5"
	16		22'-3"	22'-3"	19'-11"	18'-2"	18'-2"	17'-5"	15'-9"	15'-9"	15'-9"
	24		18'-2"	18'-2"	17'-5"	14'-10"	14'-10"	14'-10"	12'-10"	12'-10"	12'-10"
600S125-33	12	33	27'-10"	26'-1"	22'-9"	22'-9"	22'-9"	19'-11"	19'-8"	19'-8"	18'-1"
	16		24'-1"	23'-8"	20'-8"	19'-8"	19'-8"	18'-1"	17'-0"	17'-0"	16'-5"
	24		19'-8"	19'-8"	18'-1"	16'-1"	16'-1"	15'-9"	13'-11"	13'-11"	13'-11"

Notes:

1. 5 psf, 7.5 psf, and 10 psf loads have NOT been reduced for strength or deflection checks. Full lateral load is applied.
2. Calculated properties are based on AISI S100-16, North American Specification for Cold-Formed Steel Structural Members.
3. Limiting heights are based on continuous support of each flange over the full length of the stud.
4. Limiting heights are based on steel properties only (non-composite).
5. Web crippling checks are based on end-one flange loading condition using 1-inch end bearing.

^a Web stiffeners are required at all support points and concentric loads.

Limiting Wall Heights | Non-Composite

Non-Composite Limiting Heights • Standard Non-Equivalent Products

Member	Spacing o.c. (in)	F _y (ksi)	5 psf			Member	Spacing o.c. (in)	F _y (ksi)	5 psf		
			L/120	L/240	L/360				L/120	L/240	L/360
250S137-33	12	33	17' 6"	13' 10"	12' 1"	350S162-33	12	33	23' 9"	18' 10"	16' 5"
250S137-33	16		15' 10"	12' 7"	11' 0"	350S162-33	16		21' 7"	17' 1"	14' 11"
250S137-33	24		13' 10"	11' 0"	9' 7"	350S162-33	24		18' 10"	14' 11"	13' 1"
250S162-33	12	33	18' 4"	14' 7"	12' 9"	350S200-33	12	33	25' 0"	19' 10"	17' 4"
250S162-33	16		16' 8"	13' 3"	11' 7"	350S200-33	16		22' 9"	18' 1"	15' 9"
250S162-33	24		14' 7"	11' 7"	10' 1"	350S200-33	24		19' 10"	15' 9"	13' 9"
250S200-33	12	33	19' 5"	15' 5"	13' 5"	350S137-43	12	33	24' 7"	19' 6"	17' 1"
250S200-33	16		17' 8"	14' 0"	12' 3"	350S137-43	16		22' 4"	17' 9"	15' 6"
250S200-33	24		15' 5"	12' 3"	10' 8"	350S137-43	24		19' 6"	15' 6"	13' 6"
250S137-43	12	33	19' 0"	15' 1"	13' 2"	350S162-43	12	33	25' 10"	20' 6"	17' 11"
250S137-43	16		17' 3"	13' 8"	11' 11"	350S162-43	16		23' 5"	18' 7"	16' 3"
250S137-43	24		15' 1"	11' 11"	10' 5"	350S162-43	24		20' 6"	16' 3"	14' 2"
250S162-43	12	33	19' 11"	15' 10"	13' 10"	350S200-43	12	33	27' 3"	21' 7"	18' 11"
250S162-43	16		18' 1"	14' 4"	12' 7"	350S200-43	16		24' 9"	19' 8"	17' 2"
250S162-43	24		15' 10"	12' 7"	11' 0"	350S200-43	24		21' 7"	17' 2"	15' 0"
250S200-43	12	33	21' 1"	16' 9"	14' 8"	350S250-43	12	33	28' 9"	22' 10"	19' 11"
250S200-43	16		19' 2"	15' 3"	13' 4"	350S250-43	16		26' 1"	20' 9"	18' 1"
250S200-43	24		16' 9"	13' 4"	11' 7"	350S250-43	24		22' 10"	18' 1"	15' 10"
250S250-43	12	33	22' 4"	17' 9"	15' 6"	350S137-54	12	50	26' 4"	20' 11"	18' 3"
250S250-43	16		20' 4"	16' 1"	14' 1"	350S137-54	16		23' 11"	19' 0"	16' 7"
250S250-43	24		17' 9"	14' 1"	12' 4"	350S137-54	24		20' 11"	16' 7"	14' 6"
250S137-54	12	50	20' 3"	16' 1"	14' 1"	350S162-54	12	50	27' 8"	21' 11"	19' 2"
250S137-54	16		18' 5"	14' 8"	12' 9"	350S162-54	16		25' 1"	19' 11"	17' 5"
250S137-54	24		16' 1"	12' 9"	11' 2"	350S162-54	24		21' 11"	17' 5"	15' 2"
250S162-54	12	50	21' 4"	16' 11"	14' 9"	350S200-54	12	50	29' 2"	23' 2"	20' 3"
250S162-54	16		19' 4"	15' 5"	13' 5"	350S200-54	16		26' 6"	21' 1"	18' 5"
250S162-54	24		16' 11"	13' 5"	11' 9"	350S200-54	24		23' 2"	18' 5"	16' 1"
250S200-54	12	50	22' 7"	17' 11"	15' 8"	350S250-54	12	50	30' 10"	24' 6"	21' 5"
250S200-54	16		20' 6"	16' 4"	14' 3"	350S250-54	16		28' 0"	22' 3"	19' 5"
250S200-54	24		17' 11"	14' 3"	12' 5"	350S250-54	24		24' 6"	19' 5"	17' 0"
250S250-54	12	50	23' 11"	19' 0"	16' 7"	350S137-68	12	50	28' 2"	22' 4"	19' 6"
250S250-54	16		21' 9"	17' 3"	15' 1"	350S137-68	16		25' 7"	20' 3"	17' 9"
250S250-54	24		19' 0"	15' 1"	13' 2"	350S137-68	24		22' 4"	17' 9"	15' 6"
250S137-68	12	50	21' 8"	17' 2"	15' 0"	350S162-68	12	50	29' 7"	23' 5"	20' 6"
250S137-68	16		19' 8"	15' 7"	13' 7"	350S162-68	16		26' 10"	21' 4"	18' 7"
250S137-68	24		17' 2"	13' 7"	11' 11"	350S162-68	24		23' 5"	18' 7"	16' 3"
250S162-68	12	50	22' 9"	18' 1"	15' 9"	350S200-68	12	50	31' 3"	24' 10"	21' 8"
250S162-68	16		20' 8"	16' 5"	14' 4"	350S200-68	16		28' 5"	22' 7"	19' 8"
250S162-68	24		18' 1"	14' 4"	12' 6"	350S200-68	24		24' 10"	19' 8"	17' 3"
250S200-68	12	50	24' 2"	19' 2"	16' 9"	350S250-68	12	50	33' 1"	26' 3"	22' 11"
250S200-68	16		21' 11"	17' 5"	15' 3"	350S250-68	16		30' 0"	23' 10"	20' 10"
250S200-68	24		19' 2"	15' 3"	13' 4"	350S250-68	24		26' 3"	20' 10"	18' 2"
250S250-68	12	50	25' 8"	20' 4"	17' 9"	362S137-33	12	33	23' 3"	18' 5"	16' 1"
250S250-68	16		23' 4"	18' 6"	16' 2"	362S137-33	16		21' 1"	16' 9"	14' 8"
250S250-68	24		20' 4"	16' 2"	14' 1"	362S137-33	24		18' 5"	14' 8"	12' 10"
350S137-33	12	33	22' 7"	17' 11"	15' 8"	362S162-33	12	33	24' 4"	19' 4"	16' 11"
350S137-33	16		20' 7"	16' 4"	14' 3"	362S162-33	16		22' 2"	17' 7"	15' 4"
350S137-33	24		17' 11"	14' 3"	12' 5"	362S162-33	24		19' 4"	15' 4"	13' 5"

Non-Composite Limiting Heights • Standard Non-Equivalent Products

Member	Spacing o.c. (in)	F _y (ksi)	5 psf			Member	Spacing o.c. (in)	F _y (ksi)	5 psf		
			L/120	L/240	L/360				L/120	L/240	L/360
362S200-33	12	33	25'9"	20'5"	17'10"	362S162-68	12	50	30'4"	24'1"	21'1"
362S200-33	16		23'4"	18'7"	16'2"	362S162-68	16		27'7"	21'11"	19'2"
362S200-33	24		20'4"	16'2"	14'2"	362S162-68	24		24'1"	19'2"	16'9"
362S300-33	12	33	26'8"	22'4"	19'6"	362S200-68	12	50	32'2"	25'6"	22'3"
362S300-33	16		23'1"	20'3"	17'9"	362S200-68	16		29'2"	23'2"	20'3"
362S300-33	24		18'10"	17'9"	15'6"	362S200-68	24		25'6"	20'3"	17'8"
362S350-33	12	33	27'3"	23'0"	20'1"	362S250-68	12	50	33'11"	26'11"	23'6"
362S350-33	16		23'7"	20'10"	18'3"	362S250-68	16		30'10"	24'6"	21'5"
362S350-33	24		19'3"	18'3"	15'11"	362S250-68	24		26'11"	21'5"	18'8"
362S137-43	12	33	25'3"	20'1"	17'6"	362S300-68	12	50	35'7"	28'3"	24'8"
362S137-43	16		23'0"	18'3"	15'11"	362S300-68	16		32'4"	25'8"	22'5"
362S137-43	24		20'1"	15'11"	13'11"	362S300-68	24		28'3"	22'5"	19'7"
362S162-43	12	33	26'6"	21'0"	18'4"	362S350-68	12	50	37'5"	29'8"	25'11"
362S162-43	16		24'1"	19'1"	16'8"	362S350-68	16		34'0"	27'0"	23'7"
362S162-43	24		21'0"	16'8"	14'7"	362S350-68	24		29'8"	23'7"	20'7"
362S200-43	12	33	28'0"	22'3"	19'5"	362S400-68	12	50	38'9"	30'9"	26'10"
362S200-43	16		25'5"	20'2"	17'8"	362S400-68	16		35'3"	27'11"	24'5"
362S200-43	24		22'3"	17'8"	15'5"	362S400-68	24		30'9"	24'5"	21'4"
362S250-43	12	33	29'6"	23'5"	20'6"	362S137-97	12	50	31'10"	25'3"	22'1"
362S250-43	16		26'10"	21'3"	18'7"	362S137-97	16		28'11"	22'11"	20'1"
362S250-43	24		23'5"	18'7"	16'3"	362S137-97	24		25'3"	20'1"	17'6"
362S300-43	12	33	30'10"	24'6"	21'5"	362S162-97	12	50	33'6"	26'7"	23'3"
362S300-43	16		28'1"	22'3"	19'5"	362S162-97	16		30'5"	24'2"	21'1"
362S300-43	24		24'6"	19'5"	17'0"	362S162-97	24		26'7"	21'1"	18'5"
362S350-43	12	33	32'5"	25'9"	22'6"	362S200-97	12	50	35'6"	28'2"	24'8"
362S350-43	16		29'6"	23'5"	20'5"	362S200-97	16		32'3"	25'8"	22'5"
362S350-43	24		24'1"	20'5"	17'10"	362S200-97	24		28'2"	22'5"	19'7"
362S137-54	12	50	27'1"	21'6"	18'9"	362S250-97	12	50	37'7"	29'10"	26'1"
362S137-54	16		24'7"	19'6"	17'1"	362S250-97	16		34'2"	27'1"	23'8"
362S137-54	24		21'6"	17'1"	14'11"	362S250-97	24		29'10"	23'8"	20'8"
362S162-54	12	50	28'5"	22'6"	19'8"	362S300-97	12	50	39'5"	31'4"	27'4"
362S162-54	16		25'10"	20'6"	17'11"	362S300-97	16		35'10"	28'5"	24'10"
362S162-54	24		22'6"	17'11"	15'7"	362S300-97	24		31'4"	24'10"	21'9"
362S200-54	12	50	30'0"	23'10"	20'10"	362S350-97	12	50	41'7"	33'0"	28'10"
362S200-54	16		27'3"	21'8"	18'11"	362S350-97	16		37'9"	30'0"	26'2"
362S200-54	24		23'10"	18'11"	16'6"	362S350-97	24		33'0"	26'2"	22'10"
362S250-54	12	50	31'8"	25'2"	21'11"	362S400-97	12	50	43'1"	34'2"	29'11"
362S250-54	16		28'9"	22'10"	19'11"	362S400-97	16		39'2"	31'1"	27'2"
362S250-54	24		25'2"	19'11"	17'5"	362S400-97	24		34'2"	27'2"	23'9"
362S300-54	12	50	33'2"	26'4"	23'0"	362S300-118	12	50	41'9"	33'1"	28'11"
362S300-54	16		30'2"	23'11"	20'11"	362S300-118	16		37'11"	30'1"	26'3"
362S300-54	24		26'4"	20'11"	18'3"	362S300-118	24		33'1"	26'3"	22'11"
362S350-54	12	50	34'10"	27'8"	24'2"	362S350-118	12	50	44'0"	34'11"	30'6"
362S350-54	16		31'8"	25'2"	21'11"	362S350-118	16		39'11"	31'9"	27'8"
362S350-54	24		27'8"	21'11"	19'2"	362S350-118	24		34'11"	27'8"	24'2"
362S137-68	12	50	28'11"	22'11"	20'1"	362S400-118	12	50	45'8"	36'3"	31'8"
362S137-68	16		26'3"	20'10"	18'3"	362S400-118	16		41'5"	32'11"	28'9"
362S137-68	24		22'11"	18'3"	15'11"	362S400-118	24		36'3"	28'9"	25'1"

Limiting Wall Heights | Non-Composite

Non-Composite Limiting Heights • Standard Non-Equivalent Products

Member	Spacing o.c. (in)	F _y (ksi)	5 psf			Member	Spacing o.c. (in)	F _y (ksi)	5 psf		
			L/120	L/240	L/360				L/120	L/240	L/360
400S137-33	12	33	25'1"	19'11"	17'5"	400S250-54	12	33	34'1"	27'1"	23'8"
400S137-33	16		22'10"	18'1"	15'10"	400S250-54	16		31'0"	24'7"	21'6"
400S137-33	24		19'6"	15'10"	13'10"	400S250-54	24		27'1"	21'6"	18'9"
400S162-33	12	33	26'3"	20'10"	18'3"	400S300-54	12	50	35'8"	28'4"	24'9"
400S162-33	16		23'11"	18'11"	16'7"	400S300-54	16		32'5"	25'9"	22'6"
400S162-33	24		20'10"	16'7"	14'6"	400S300-54	24		28'4"	22'6"	19'8"
400S200-33	12	33	27'9"	22'0"	19'3"	400S350-54	12	50	37'6"	29'9"	26'0"
400S200-33	16		25'2"	20'0"	17'6"	400S350-54	16		34'1"	27'1"	23'8"
400S200-33	24		21'11"	17'6"	15'3"	400S350-54	24		29'9"	23'8"	20'8"
400S300-33	12	33	28'3"	24'0"	21'0"	400S400-54	12	50	37'9"	30'0"	26'2"
400S300-33	16		24'6"	21'10"	19'1"	400S400-54	16		34'4"	27'3"	23'10"
400S300-33	24		20'0"	19'1"	16'8"	400S400-54	24		30'0"	23'10"	20'10"
400S350-33	12	33	28'11"	24'8"	21'7"	400S137-68	12	50	31'3"	24'10"	21'8"
400S350-33	16		25'1"	22'5"	19'7"	400S137-68	16		28'5"	22'7"	19'8"
400S350-33	24		20'6"	19'7"	17'2"	400S137-68	24		24'10"	19'8"	17'2"
400S400-33	12	33	29'1"	25'1"	21'11"	400S162-68	12	50	32'10"	26'0"	22'9"
400S400-33	16		25'2"	22'10"	19'11"	400S162-68	16		29'10"	23'8"	20'8"
400S400-33	24		20'7"	19'11"	17'5"	400S162-68	24		26'0"	20'8"	18'1"
400S137-43	12	33	27'4"	21'8"	18'11"	400S200-68	12	50	34'8"	27'6"	24'0"
400S137-43	16		24'10"	19'8"	17'2"	400S200-68	16		31'6"	25'0"	21'10"
400S137-43	24		21'8"	17'2"	15'0"	400S200-68	24		27'6"	21'10"	19'1"
400S162-43	12	33	28'7"	22'8"	19'10"	400S250-68	12	50	36'7"	29'0"	25'4"
400S162-43	16		26'0"	20'7"	18'0"	400S250-68	16		33'3"	26'4"	23'0"
400S162-43	24		22'8"	18'0"	15'9"	400S250-68	24		29'0"	23'0"	20'1"
400S200-43	12	33	30'2"	23'11"	20'11"	400S300-68	12	50	38'3"	30'5"	26'7"
400S200-43	16		27'5"	21'9"	19'0"	400S300-68	16		34'9"	27'7"	24'1"
400S200-43	24		23'11"	19'0"	16'7"	400S300-68	24		30'5"	24'1"	21'1"
400S250-43	12	33	31'9"	25'3"	22'0"	400S350-68	12	50	40'3"	32'0"	27'11"
400S250-43	16		28'10"	22'11"	20'0"	400S350-68	16		36'7"	29'0"	25'4"
400S250-43	24		25'3"	20'0"	17'6"	400S350-68	24		32'0"	25'4"	22'2"
400S300-43	12	33	33'2"	26'4"	23'0"	400S400-68	12	50	41'8"	33'1"	28'11"
400S300-43	16		30'1"	23'11"	20'11"	400S400-68	16		37'11"	30'1"	26'3"
400S300-43	24		26'4"	20'11"	18'3"	400S400-68	24		33'1"	26'3"	22'11"
400S350-43	12	33	34'11"	27'9"	24'3"	400S137-97	12	50	34'5"	27'4"	23'11"
400S350-43	16		31'4"	25'2"	22'0"	400S137-97	16		31'3"	24'10"	21'8"
400S350-43	24		25'7"	22'0"	19'3"	400S137-97	24		27'4"	21'8"	18'11"
400S400-43	12	33	35'9"	28'4"	24'9"	400S162-97	12	50	36'3"	28'9"	25'1"
400S400-43	16		31'6"	25'9"	22'6"	400S162-97	16		32'11"	26'1"	22'10"
400S400-43	24		25'9"	22'6"	19'8"	400S162-97	24		28'9"	22'10"	19'11"
400S137-54	12	33	29'3"	23'2"	20'3"	400S200-97	12	50	38'4"	30'5"	26'7"
400S137-54	16		26'7"	21'1"	18'5"	400S200-97	16		34'10"	27'8"	24'2"
400S137-54	24		23'2"	18'5"	16'1"	400S200-97	24		30'5"	24'2"	21'1"
400S162-54	12	33	30'8"	24'4"	21'3"	400S250-97	12	50	40'7"	32'2"	28'1"
400S162-54	16		27'10"	22'1"	19'4"	400S250-97	16		36'10"	29'3"	25'6"
400S162-54	24		24'4"	19'4"	16'10"	400S250-97	24		32'2"	25'6"	22'4"
400S200-54	12	33	32'4"	25'8"	22'5"	400S300-97	12	50	42'6"	33'9"	29'6"
400S200-54	16		29'5"	23'4"	20'5"	400S300-97	16		38'7"	30'8"	26'9"
400S200-54	24		25'8"	20'5"	17'10"	400S300-97	24		33'9"	26'9"	23'5"

Non-Composite Limiting Heights • Standard Non-Equivalent Products

Member	Spacing o.c. (in)	F _y (ksi)	5 psf			Member	Spacing o.c. (in)	F _y (ksi)	5 psf		
			L/120	L/240	L/360				L/120	L/240	L/360
400S350-97	12	50	44'9"	35'6"	31'1"	550S137-68	12	50	40'4"	32'0"	28'0"
400S350-97	16		40'8"	32'3"	28'2"	550S137-68	16		36'8"	29'1"	25'5"
400S350-97	24		35'6"	28'2"	24'8"	550S137-68	24		32'0"	25'5"	22'2"
400S400-97	12	50	46'5"	36'10"	32'2"	550S162-68	12	50	42'2"	33'6"	29'3"
400S400-97	16		42'2"	33'5"	29'3"	550S162-68	16		38'4"	30'5"	26'7"
400S400-97	24		36'10"	29'3"	25'6"	550S162-68	24		33'6"	26'7"	23'3"
400S300-118	12	50	44'11"	35'8"	31'2"	550S200-68	12	50	44'5"	35'3"	30'10"
400S300-118	16		40'10"	32'5"	28'4"	550S200-68	16		40'4"	32'0"	28'0"
400S300-118	24		35'8"	28'4"	24'9"	550S200-68	24		35'3"	28'0"	24'5"
400S350-118	12	50	47'5"	37'8"	32'10"	550S250-68	12	50	46'8"	37'0"	32'4"
400S350-118	16		43'1"	34'2"	29'10"	550S250-68	16		42'4"	33'7"	29'4"
400S350-118	24		37'8"	29'10"	26'1"	550S250-68	24		37'0"	29'4"	25'8"
400S400-118	12	50	49'2"	39'0"	34'1"	550S137-97	12	50	44'7"	35'5"	30'11"
400S400-118	16		44'8"	35'5"	31'0"	550S137-97	16		40'6"	32'2"	28'1"
400S400-118	24		39'0"	31'0"	27'1"	550S137-97	24		35'5"	28'1"	24'6"
550S137-33	12	33	32'3"	25'7"	22'5"	550S162-97	12	50	46'8"	37'1"	32'5"
550S137-33	16		28'10"	23'3"	20'4"	550S162-97	16		42'5"	33'8"	29'5"
550S137-33	24		23'7"	20'4"	17'9"	550S162-97	24		37'1"	29'5"	25'8"
550S162-33	12	33	33'8"	26'9"	23'4"	550S200-97	12	50	49'3"	39'1"	34'2"
550S162-33	16		30'7"	24'4"	21'3"	550S200-97	16		44'9"	35'6"	31'1"
550S162-33	24		25'3"	21'3"	18'6"	550S200-97	24		39'1"	31'1"	27'1"
550S200-33	12	33	35'5"	28'1"	24'7"	550S250-97	12	50	51'10"	41'1"	35'11"
550S200-33	16		32'2"	25'6"	22'4"	550S250-97	16		47'1"	37'4"	32'8"
550S200-33	24		26'11"	22'4"	19'6"	550S250-97	24		41'1"	32'8"	28'6"
550S137-43	12	33	35'2"	27'11"	24'4"	600S137-33	12	33	34'5"	27'6"	24'0"
550S137-43	16		31'11"	25'4"	22'2"	600S137-33	16		30'2"	24'11"	21'10"
550S137-43	24		27'11"	22'2"	19'4"	600S137-33	24		24'7"	21'9"	19'1"
550S162-43	12	33	36'8"	29'1"	25'5"	600S162-33	12	33	36'1"	28'8"	25'0"
550S162-43	16		33'4"	26'5"	23'1"	600S162-33	16		32'5"	26'0"	22'9"
550S162-43	24		29'1"	23'1"	20'2"	600S162-33	24		26'6"	22'9"	19'10"
550S200-43	12	33	38'7"	30'7"	26'9"	600S200-33	12	33	37'11"	30'1"	26'3"
550S200-43	16		35'1"	27'10"	24'4"	600S200-33	16		34'4"	27'4"	23'10"
550S200-43	24		30'7"	24'4"	21'3"	600S200-33	24		28'3"	23'10"	20'10"
550S250-43	12	33	40'5"	32'1"	28'1"	600S300-33	12	33	34'8"	31'10"	27'10"
550S250-43	16		36'9"	29'2"	25'6"	600S300-33	16		30'0"	28'11"	25'3"
550S250-43	24		32'1"	25'6"	22'3"	600S300-33	24		24'6"	24'6"	22'1"
550S137-54	12	50	37'8"	29'11"	26'1"	600S350-33	12	33	36'5"	33'1"	28'11"
550S137-54	16		34'3"	27'2"	23'9"	600S350-33	16		31'7"	30'1"	26'3"
550S137-54	24		29'11"	23'9"	20'9"	600S350-33	24		25'9"	25'9"	23'0"
550S162-54	12	50	39'4"	31'3"	27'3"	600S400-33	12	33	37'0"	33'9"	29'6"
550S162-54	16		35'9"	28'5"	24'9"	600S400-33	16		32'0"	30'8"	26'9"
550S162-54	24		31'3"	24'9"	21'8"	600S400-33	24		26'2"	26'2"	23'5"
550S200-54	12	50	41'5"	32'10"	28'8"	600S137-43	12	33	37'8"	29'11"	26'2"
550S200-54	16		37'7"	29'10"	26'1"	600S137-43	16		34'3"	27'2"	23'9"
550S200-54	24		32'10"	26'1"	22'9"	600S137-43	24		29'7"	23'9"	20'9"
550S250-54	12	50	43'5"	34'6"	30'1"	600S162-43	12	33	39'4"	31'2"	27'3"
550S250-54	16		39'6"	31'4"	27'4"	600S162-43	16		35'9"	28'4"	24'9"
550S250-54	24		34'6"	27'4"	23'11"	600S162-43	24		31'2"	24'9"	21'8"

Limiting Wall Heights | Non-Composite

Non-Composite Limiting Heights • Standard Non-Equivalent Products

Member	Spacing o.c. (in)	F _y (ksi)	5 psf			Member	Spacing o.c. (in)	F _y (ksi)	5 psf		
			L/120	L/240	L/360				L/120	L/240	L/360
600S200-43	12	33	41'3"	32'9"	28'7"	600S300-68	12	50	52'0"	41'3"	36'0"
600S200-43	16		37'6"	29'9"	26'0"	600S300-68	16		47'3"	37'6"	32'9"
600S200-43	24		32'9"	26'0"	22'9"	600S300-68	24		41'3"	32'9"	28'7"
600S250-43	12	33	43'3"	34'4"	30'0"	600S350-68	12	50	54'8"	43'5"	37'11"
600S250-43	16		39'3"	31'2"	27'3"	600S350-68	16		49'8"	39'5"	34'5"
600S250-43	24		34'4"	27'3"	23'10"	600S350-68	24		43'5"	34'5"	30'1"
600S300-43	12	33	44'5"	35'3"	30'10"	600S400-68	12	50	56'6"	44'10"	39'2"
600S300-43	16		40'4"	32'1"	28'0"	600S400-68	16		51'4"	40'9"	35'7"
600S300-43	24		33'5"	28'0"	24'5"	600S400-68	24		44'10"	35'7"	31'1"
600S350-43	12	33	45'7"	37'6"	32'9"	600S137-97	12	50	47'11"	38'0"	33'2"
600S350-43	16		39'5"	34'0"	29'9"	600S137-97	16		43'6"	34'6"	30'2"
600S350-43	24		32'3"	29'9"	26'0"	600S137-97	24		38'0"	30'2"	26'4"
600S400-43	12	33	46'3"	38'2"	33'4"	600S162-97	12	50	50'1"	39'9"	34'9"
600S400-43	16		40'1"	34'8"	30'4"	600S162-97	16		45'6"	36'2"	31'7"
600S400-43	24		32'9"	30'4"	26'6"	600S162-97	24		39'9"	31'7"	27'7"
600S137-54	12	50	40'5"	32'1"	28'0"	600S200-97	12	50	52'10"	41'11"	36'7"
600S137-54	16		36'9"	29'2"	25'6"	600S200-97	16		48'0"	38'1"	33'3"
600S137-54	24		32'1"	25'6"	22'3"	600S200-97	24		41'11"	33'3"	29'1"
600S162-54	12	50	42'2"	33'6"	29'3"	600S250-97	12	50	55'5"	44'0"	38'5"
600S162-54	16		38'4"	30'5"	26'7"	600S250-97	16		50'4"	40'0"	34'11"
600S162-54	24		33'6"	26'7"	23'3"	600S250-97	24		44'0"	34'11"	30'6"
600S200-54	12	50	44'4"	35'2"	30'9"	600S300-97	12	50	57'10"	45'11"	40'1"
600S200-54	16		40'3"	32'0"	27'11"	600S300-97	16		52'7"	41'9"	36'5"
600S200-54	24		35'2"	27'11"	24'5"	600S300-97	24		45'11"	36'5"	31'10"
600S250-54	12	50	46'5"	36'10"	32'2"	600S350-97	12	50	60'11"	48'4"	42'3"
600S250-54	16		42'2"	33'6"	29'3"	600S350-97	16		55'4"	43'11"	38'5"
600S250-54	24		36'10"	29'3"	25'7"	600S350-97	24		48'4"	38'5"	33'6"
600S300-54	12	50	48'5"	38'5"	33'7"	600S400-97	12	50	62'11"	50'0"	43'8"
600S300-54	16		43'11"	34'11"	30'6"	600S400-97	16		57'2"	45'5"	39'8"
600S300-54	24		38'4"	30'6"	26'8"	600S400-97	24		50'0"	39'8"	34'8"
600S350-54	12	50	50'11"	40'5"	35'3"	600S300-118	12	50	61'4"	48'8"	42'6"
600S350-54	16		46'3"	36'8"	32'1"	600S300-118	16		55'8"	44'2"	38'7"
600S350-54	24		40'4"	32'1"	28'0"	600S300-118	24		48'8"	38'7"	33'9"
600S400-54	12	50	51'10"	41'2"	36'0"	600S350-118	12	50	64'8"	51'4"	44'10"
600S400-54	16		47'2"	37'5"	32'8"	600S350-118	16		58'9"	46'7"	40'9"
600S400-54	24		41'2"	32'8"	28'7"	600S350-118	24		51'4"	40'9"	35'7"
600S137-68	12	50	43'4"	34'4"	30'0"	600S400-118	12	50	66'10"	53'0"	46'4"
600S137-68	16		39'4"	31'3"	27'3"	600S400-118	16		60'8"	48'2"	42'1"
600S137-68	24		34'4"	27'3"	23'10"	600S400-118	24		53'0"	42'1"	36'9"
600S162-68	12	50	45'3"	35'11"	31'4"	800S137-33	12	33	39'10"	34'3"	30'2"
600S162-68	16		41'1"	32'7"	28'6"	800S137-33	16		34'6"	31'1"	27'4"
600S162-68	24		35'11"	28'6"	24'11"	800S137-33	24		28'2"	27'1"	23'10"
600S200-68	12	50	47'7"	37'9"	33'0"	800S162-33	12	33	43'3"	35'8"	31'4"
600S200-68	16		43'2"	34'3"	29'11"	800S162-33	16		37'5"	32'4"	28'5"
600S200-68	24		37'9"	29'11"	26'2"	800S162-33	24		30'7"	28'2"	24'9"
600S250-68	12	50	49'10"	39'7"	34'7"	800S200-33	12	33	46'5"	37'9"	33'0"
600S250-68	16		45'4"	35'11"	31'5"	800S200-33	16		40'2"	34'3"	29'11"
600S250-68	24		39'7"	31'5"	27'5"	800S200-33	24		32'10"	29'11"	26'2"

Non-Composite Limiting Heights • Standard Non-Equivalent Products

Member	Spacing o.c. (in)	F _y (ksi)	5 psf			Member	Spacing o.c. (in)	F _y (ksi)	5 psf		
			L/120	L/240	L/360				L/120	L/240	L/360
800S137-43	12	33	47'3"	37'10"	33'1"	800S200-68	12	50	59'9"	47'5"	41'5"
800S137-43	16		41'10"	34'4"	30'0"	800S200-68	16		54'4"	43'1"	37'8"
800S137-43	24		34'2"	29'11"	26'3"	800S200-68	24		47'5"	37'8"	32'11"
800S162-43	12	33	49'2"	39'4"	34'4"	800S250-68	12	50	62'5"	49'6"	43'3"
800S162-43	16		44'7"	35'8"	31'2"	800S250-68	16		56'8"	45'0"	39'4"
800S162-43	24		36'10"	31'1"	27'3"	800S250-68	24		49'6"	39'4"	34'4"
800S200-43	12	33	51'10"	41'1"	35'11"	800S300-68	12	50	64'10"	51'5"	44'11"
800S200-43	16		47'1"	37'4"	32'8"	800S300-68	16		58'11"	46'9"	40'10"
800S200-43	24		39'5"	32'8"	28'6"	800S300-68	24		51'5"	40'10"	35'8"
800S250-43	12	33	54'0"	42'11"	37'6"	800S350-68	12	50	68'1"	54'1"	47'3"
800S250-43	16		49'1"	39'0"	34'0"	800S350-68	16		61'11"	49'1"	42'11"
800S250-43	24		40'5"	34'0"	29'9"	800S350-68	24		54'1"	42'11"	37'6"
800S300-43	12	33	52'6"	42'7"	37'2"	800S400-68	12	50	70'2"	55'8"	48'8"
800S300-43	16		45'5"	38'8"	33'9"	800S400-68	16		63'9"	50'7"	44'2"
800S300-43	24		37'1"	33'9"	29'6"	800S400-68	24		55'8"	44'2"	38'7"
800S350-43	12	33	52'10"	46'0"	40'2"	800S137-97	12	50	60'10"	48'4"	42'2"
800S350-43	16		45'9"	41'9"	36'6"	800S137-97	16		55'4"	43'11"	38'4"
800S350-43	24		37'5"	36'6"	31'10"	800S137-97	24		48'4"	38'4"	33'6"
800S400-43	12	33	52'9"	46'6"	40'7"	800S162-97	12	50	63'5"	50'4"	43'11"
800S400-43	16		45'8"	42'3"	36'11"	800S162-97	16		57'7"	45'9"	39'11"
800S400-43	24		37'3"	36'11"	32'3"	800S162-97	24		50'4"	39'11"	34'11"
800S137-54	12	50	51'2"	40'7"	35'6"	800S200-97	12	50	66'6"	52'9"	46'1"
800S137-54	16		46'5"	36'11"	32'3"	800S200-97	16		60'5"	47'11"	41'11"
800S137-54	24		40'6"	32'3"	28'2"	800S200-97	24		52'9"	41'11"	36'7"
800S162-54	12	50	53'2"	42'3"	36'10"	800S250-97	12	50	69'6"	55'2"	48'2"
800S162-54	16		48'4"	38'4"	33'6"	800S250-97	16		63'1"	50'1"	43'9"
800S162-54	24		42'1"	33'6"	29'3"	800S250-97	24		55'2"	43'9"	38'3"
800S200-54	12	50	55'8"	44'2"	38'7"	800S300-97	12	50	72'3"	57'4"	50'1"
800S200-54	16		50'7"	40'2"	35'1"	800S300-97	16		65'8"	52'1"	45'6"
800S200-54	24		44'2"	35'1"	30'8"	800S300-97	24		57'4"	45'6"	39'9"
800S250-54	12	50	58'1"	46'1"	40'3"	800S350-97	12	50	76'0"	60'4"	52'8"
800S250-54	16		52'9"	41'10"	36'7"	800S350-97	16		69'1"	54'10"	47'10"
800S250-54	24		46'1"	36'7"	31'11"	800S350-97	24		60'4"	47'10"	41'10"
800S300-54	12	50	60'4"	47'10"	41'10"	800S400-97	12	50	78'4"	62'2"	54'4"
800S300-54	16		54'9"	43'6"	38'0"	800S400-97	16		71'2"	56'6"	49'4"
800S300-54	24		47'8"	38'0"	33'2"	800S400-97	24		62'2"	49'4"	43'1"
800S350-54	12	50	63'4"	50'3"	43'11"	800S300-118	12	50	76'8"	60'10"	53'2"
800S350-54	16		57'6"	45'8"	39'11"	800S300-118	16		69'8"	55'3"	48'3"
800S350-54	24		50'1"	39'11"	34'10"	800S300-118	24		60'10"	48'3"	42'2"
800S400-54	12	50	61'11"	49'2"	42'11"	800S350-118	12	50	80'8"	64'1"	55'11"
800S400-54	16		56'3"	44'8"	39'0"	800S350-118	16		73'4"	58'2"	50'10"
800S400-54	24		49'2"	39'0"	34'1"	800S350-118	24		64'1"	50'10"	44'5"
800S137-68	12	50	54'11"	43'7"	38'1"	800S400-118	12	50	83'2"	66'0"	57'8"
800S137-68	16		49'10"	39'7"	34'7"	800S400-118	16		75'7"	60'0"	52'5"
800S137-68	24		43'7"	34'7"	30'2"	800S400-118	24		66'0"	52'5"	45'9"
800S162-68	12	50	57'1"	45'4"	39'7"						
800S162-68	16		51'10"	41'2"	35'11"						
800S162-68	24		45'4"	35'11"	31'5"						

Notes:
See table notes on page 18.

Ceiling Spans

Ceiling Span Diagrams

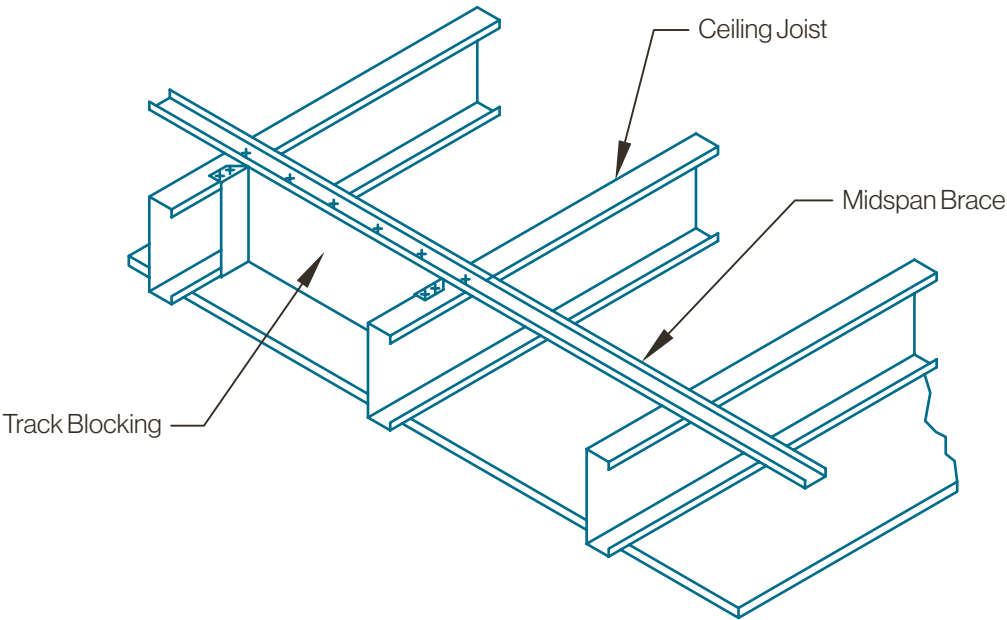
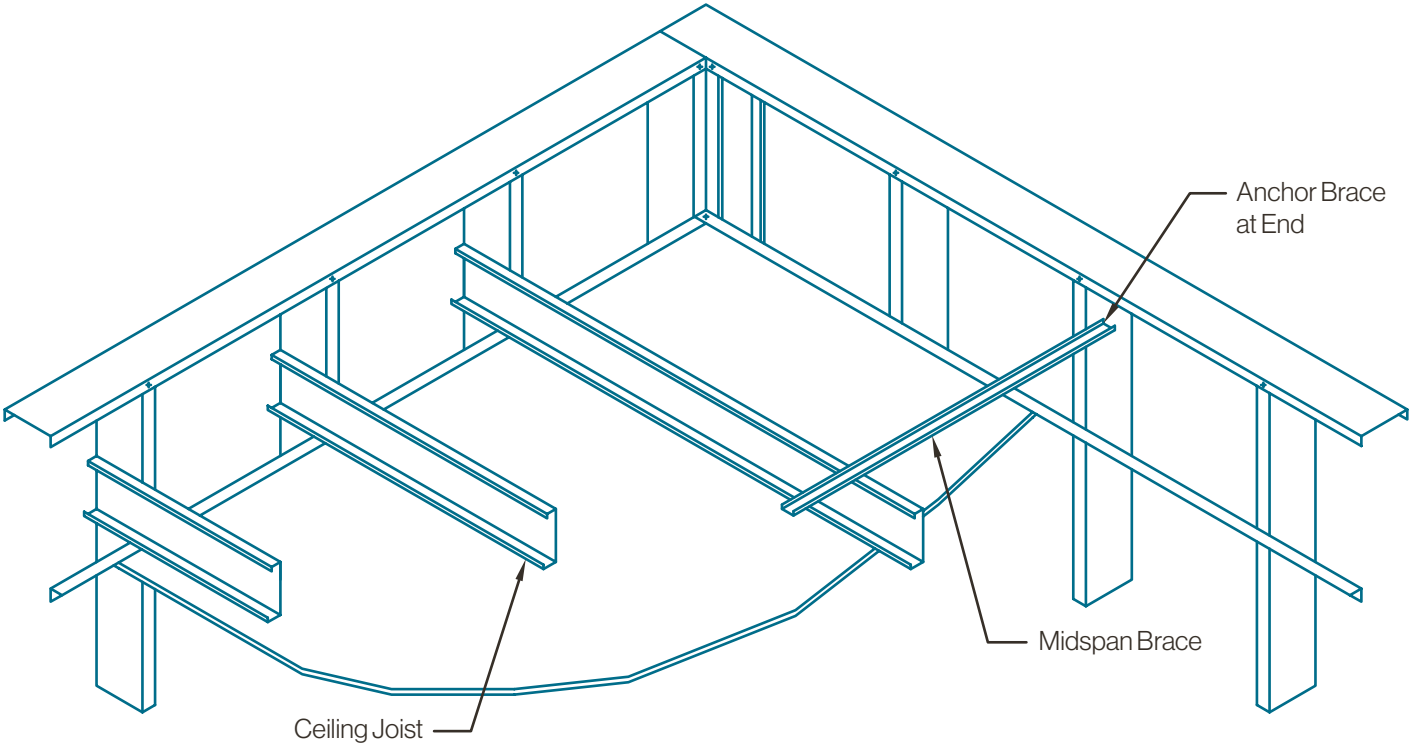

Allowable Ceiling Spans • Deflection Limit L/240 • Standard Non-Equivalent Products

Section	F _y (ksi)	4 psf						6 psf						13 psf						
		Lateral Support of Compression Flange			Lateral Support of Compression Flange			Lateral Support of Compression Flange			Lateral Support of Compression Flange			Lateral Support of Compression Flange			Lateral Support of Compression Flange			
		Unsupported Joist Spacing (in) o.c.		Midspan Joist Spacing (in) o.c.	Unsupported Joist Spacing (in) o.c.		Midspan Joist Spacing (in) o.c.	Unsupported Joist Spacing (in) o.c.		Midspan Joist Spacing (in) o.c.	Unsupported Joist Spacing (in) o.c.		Midspan Joist Spacing (in) o.c.	Unsupported Joist Spacing (in) o.c.		Midspan Joist Spacing (in) o.c.	Unsupported Joist Spacing (in) o.c.		Midspan Joist Spacing (in) o.c.	
12	16	24	12	16	24	12	16	24	12	16	24	12	16	24	12	16	24	12	16	24
162S125-18	33	7'3"	6'7"	5'10"	8'6"	7'8"	6'7"	6'5"	5'10"	5'1"	7'4"	6'7"	5'8"	5'0"	4'5"	3'9"	5'6"	4'9"	3'10"	
162S125-27	33	8'7"	7'11"	7'1"	9'8"	8'10"	7'8"	7'8"	7'1"	6'3"	8'6"	7'8"	6'8"	6'1"	5'6"	4'9"	6'6"	5'11"	5'1"	
162S125-30	33	9'0"	8'3"	7'4"	10'0"	9'1"	7'11"	8'0"	7'4"	6'7"	8'9"	7'11"	6'11"	6'5"	5'10"	5'0"	6'9"	6'1"	5'4"	
162S125-33	33	9'6"	8'8"	7'8"	10'4"	9'5"	8'2"	8'4"	7'8"	6'10"	9'0"	8'2"	7'2"	6'8"	6'1"	5'4"	7'0"	6'4"	5'6"	
162S137-27	33	9'11"	9'2"	8'0"	10'1"	9'2"	8'0"	8'10"	8'0"	7'0"	8'10"	8'0"	7'0"	6'10"	6'2"	5'5"	6'10"	6'2"	5'5"	
162S137-30	33	10'4"	9'6"	8'3"	10'5"	9'6"	8'3"	9'1"	8'3"	7'3"	9'1"	8'3"	7'3"	7'0"	6'5"	5'7"	7'0"	6'5"	5'7"	
162S137-33	33	10'9"	9'9"	8'7"	10'9"	9'9"	8'7"	9'5"	8'7"	7'6"	9'5"	8'7"	7'6"	7'3"	6'7"	5'9"	7'3"	6'7"	5'9"	
250S125-18	33	8'5"	7'9"	6'11"	11'7"	10'6"	8'10"	7'6"	6'11"	6'2"	10'1"	8'10"	7'2"	6'0"	5'6"	4'10"	6'11"	6'0"	4'11"	
250S125-27	33	9'8"	8'11"	8'0"	13'5"	12'2"	10'7"	8'8"	8'0"	7'2"	11'8"	10'7"	9'3"	7'0"	6'6"	5'9"	9'0"	7'11"	6'6"	
250S125-30	33	10'1"	9'3"	8'3"	13'10"	12'7"	10'11"	9'0"	8'3"	7'5"	12'1"	10'11"	9'7"	7'3"	6'8"	6'0"	9'4"	8'5"	6'11"	
250S125-33	33	10'6"	9'8"	8'7"	14'3"	13'0"	11'4"	9'4"	8'7"	7'8"	12'6"	11'4"	9'11"	7'6"	6'11"	6'2"	9'7"	8'9"	7'5"	
250S125-43	33	11'9"	10'10"	9'7"	15'6"	14'1"	12'4"	10'5"	9'7"	8'6"	13'7"	12'4"	10'9"	8'4"	7'8"	6'10"	10'6"	9'6"	8'4"	
250S137-27	33	11'0"	10'2"	9'2"	14'0"	12'9"	11'1"	9'10"	9'2"	8'2"	12'3"	11'1"	9'9"	8'0"	7'5"	6'8"	9'6"	8'7"	7'6"	
250S137-30	33	11'5"	10'6"	9'5"	14'5"	13'2"	11'6"	10'2"	9'5"	8'5"	12'8"	11'6"	10'0"	8'3"	7'8"	6'10"	9'9"	8'10"	7'9"	
250S137-33	33	11'10"	10'11"	9'9"	14'11"	13'7"	11'10"	10'7"	9'9"	8'9"	13'1"	11'10"	10'4"	8'7"	7'11"	7'1"	10'1"	9'2"	8'0"	
250S137-43	33	13'3"	12'2"	10'10"	16'3"	14'9"	12'11"	11'9"	10'10"	9'7"	14'2"	12'11"	11'3"	9'5"	8'8"	7'9"	10'11"	9'11"	8'8"	
250S162-33	33	13'6"	12'5"	11'2"	15'8"	14'3"	12'5"	12'1"	11'2"	10'0"	13'8"	12'5"	10'10"	9'10"	9'1"	8'1"	10'7"	9'7"	8'5"	
250S162-43	33	15'0"	13'9"	12'3"	17'1"	15'6"	13'6"	13'4"	12'3"	10'11"	14'11"	13'6"	11'10"	10'8"	9'11"	8'10"	11'6"	10'5"	9'2"	
350S125-18	33	9'2"	8'6"	7'6"	12'6"	11'5"	9'11"	8'3"	7'6"	6'8"	11'0"	9'11"	8'5"	6'6"	5'11"	5'3"	8'2"	7'2"	5'10"	
350S125-27	33	10'7"	9'9"	8'9"	14'11"	13'9"	12'3"	9'5"	8'9"	7'9"	13'4"	12'3"	10'7"	7'7"	7'1"	6'4"	10'4"	9'3"	7'9"	
350S125-30	33	10'11"	10'1"	9'0"	15'5"	14'2"	12'9"	9'9"	9'0"	8'1"	13'9"	12'9"	11'2"	7'11"	7'3"	6'6"	10'11"	9'9"	8'3"	
350S125-33	33	11'4"	10'5"	9'4"	16'0"	14'9"	13'2"	10'1"	9'4"	8'4"	14'3"	13'2"	11'9"	8'2"	7'7"	6'9"	11'5"	10'4"	8'10"	
350S125-43	33	12'7"	11'7"	10'4"	17'7"	16'3"	14'6"	11'2"	10'4"	9'2"	15'8"	14'6"	12'11"	9'0"	8'3"	7'5"	12'7"	11'6"	10'1"	
350S137-27	33	11'11"	11'0"	9'11"	17'0"	15'9"	14'1"	10'8"	9'11"	8'11"	15'3"	14'1"	12'4"	8'8"	8'1"	7'3"	11'11"	10'7"	8'11"	
350S137-30	33	12'4"	11'5"	10'3"	17'7"	16'3"	14'7"	11'0"	10'3"	9'2"	15'9"	14'7"	12'10"	9'0"	8'4"	7'6"	12'6"	11'3"	9'6"	
350S137-33	33	12'9"	11'10"	10'7"	18'2"	16'9"	15'1"	11'5"	10'7"	9'6"	16'3"	15'1"	13'4"	9'3"	8'7"	7'8"	13'0"	11'9"	10'0"	
350S137-43	33	14'2"	13'0"	11'7"	19'10"	18'4"	16'5"	12'7"	11'7"	10'4"	17'9"	16'5"	14'7"	10'2"	9'4"	8'5"	14'2"	12'11"	11'3"	
350S162-33	33	14'6"	13'5"	12'1"	20'3"	18'5"	16'1"	13'0"	12'1"	10'10"	17'9"	16'1"	14'1"	10'7"	9'10"	8'10"	13'8"	12'5"	10'10"	
350S162-43	33	16'0"	14'9"	13'2"	22'1"	20'0"	17'6"	14'3"	13'2"	11'9"	19'3"	17'6"	15'3"	11'6"	10'8"	9'7"	14'11"	13'6"	11'10"	
362S125-18	33	9'3"	8'7"	7'7"	12'8"	11'7"	10'0"	8'4"	7'7"	6'9"	11'1"	10'0"	8'6"	6'7"	6'0"	5'4"	8'3"	7'4"	6'0"	
362S125-27	33	10'8"	9'10"	8'10"	15'0"	13'11"	12'4"	9'6"	8'10"	7'10"	13'5"	12'4"	10'9"	7'8"	7'1"	6'5"	10'5"	9'4"	7'11"	
362S125-30	33	11'0"	10'2"	9'1"	15'6"	14'4"	12'10"	9'10"	9'1"	8'2"	13'11"	12'10"	11'4"	8'0"	7'4"	6'7"	11'0"	9'11"	8'5"	
362S125-33	33	11'5"	10'7"	9'5"	16'2"	14'10"	13'3"	10'3"	9'5"	8'5"	14'5"	13'3"	11'10"	8'3"	7'8"	6'10"	11'7"	10'6"	9'0"	
362S125-43	33	12'8"	11'8"	10'5"	17'9"	16'5"	14'8"	11'3"	10'5"	9'3"	15'10"	14'8"	13'0"	9'1"	8'4"	7'6"	12'9"	11'8"	10'2"	
362S137-27	33	12'0"	11'2"	10'0"	17'2"	15'11"	14'3"	10'10"	10'0"	9'0"	15'5"	14'3"	12'6"	8'9"	8'2"	7'4"	12'1"	10'9"	9'1"	
362S137-30	33	12'5"	11'6"	10'4"	17'8"	16'5"	14'8"	11'2"	10'4"	9'3"	15'10"	14'8"	13'0"	9'1"	8'5"	7'6"	12'8"	11'5"	9'8"	
362S137-33	33	12'11"	11'11"	10'8"	18'4"	16'11"	15'2"	11'6"	10'8"	9'7"	16'5"	15'2"	13'6"	9'4"	8'8"	7'9"	13'2"	11'11"	10'2"	
362S137-43	33	14'3"	13'2"	11'8"	20'0"	18'6"	16'7"	12'8"	11'8"	10'5"	17'11"	16'7"	14'9"	10'3"	9'5"	8'6"	14'5"	13'2"	11'5"	
362S162-33	33	14'8"	13'7"	12'2"	20'10"	18'11"	16'6"	13'2"	12'2"	10'11"	18'2"	16'6"	14'5"	10'8"	9'11"	8'11"	14'1"	12'9"	11'2"	
362S162-43	33	16'2"	14'11"	13'4"	22'8"	20'7"	18'0"	14'5"	13'4"	11'11"	19'10"	18'0"	15'9"	11'8"	10'9"	9'8"	15'4"	13'11"	12'2"	
400S125-18	33	9'6"	8'9"	7'10"	13'0"	11'11"	10'5"	8'6"	7'10"	6'11"	11'6"	10'5"	8'11"	6'9"	6'2"	5'6"	8'7"	7'8"	6'4"	
400S125-27	33	10'11"	10'1"	9'1"	15'5"	14'3"	12'9"	9'9"	9'1"	8'1"	13'10"	12'9"	11'2"	7'11"	7'4"	6'7"	10'10"	9'9"	8'3"	
400S125-30	33	11'4"	10'5"	9'4"	16'0"	14'9"	13'2"	10'1"	9'4"	8'4"	14'3"	13'2"	11'9"	8'2"	7'7"	6'9"	11'5"	10'4"	8'9"	
400S125-33	33	11'9"	10'10"	9'8"	16'7"	15'3"	13'8"	10'6"	9'8"	8'8"	14'9"	13'8"	12'2"	8'6"	7'10"	7'0"	11'11"	10'11"	9'4"	
400S125-43	33	13'0"	12'0"	10'8"	18'3"	16'10"	15'0"	11'7"	10'8"	9'6"	16'3"	15'0"	13'5"	9'4"	8'7"	7'8"	13'1"	12'0"	10'7"	
400S137-27	33	12'4"	11'5"	10'3"	17'7"	16'4"	14'8"	11'1"	10'3"	9'2"	15'10"	14'8"	13'0"	9'0"	8'4"	7'6"	12'7"	11'3"	9'6"	
400S137-30	33	12'9"	11'10"	10'7"	18'2"	16'10"	15'1"	11'5"	10'7"	9'6"	16'4"	15'1"	13'5"	9'3"	8'7"	7'9"	13'1"	11'10"	10'1"	
400S137-33	33	13'3"	12'3"	11'11"	18'9"	17'4"	15'7"	11'10"	10'11"	9'10"	16'10"	15'7"	13'11"	9'7"	8'11"	8'0"	13'7"	12'4"	10'8"	
400S137-43	33	14'7"	13'6"	12'0"	20'7"	19'0"	17'0"	13'0"	12'0"	10'9"	18'4"	17'0"	15'2"	10'6"	9'8"	8'8"	14'10"	13'7"	11'10"	
400S162-33	33	15'0"	13'11"	12'6"	21'5"	19'10"	17'9"	13'6"	12'6"	11'2"	19'3"	17'9"	15'7"	10'11"	10'2"	9'1"	15'2"	13'9"	11'9"	
400S162-43	33	16'7"	15'3"	13'8"	23'4"	21'7"	19'4"	14'9"	13'8"	12'2"	20'11"	19'4"	16'11"	11'11"	11'0"	9'11"	16'6"	15'0"	13'1"	
550S125-27	33	12'1"	11'3"	10'1"	17'6"	16'1"	14'5"	10'11"	10'1"	9'1"	15'7"	14'5"	12'11"	8'11"	8'3"	7'5"	12'7"	11'7"	10'0"	
550S125-30	33	12'6"	11'7"	10'5"	17'11"	16'8"	14'11"	11'2"	10'5"	9'4"	16'2"	14'11"	13'4"	9'2"	8'6"	7'8"	13'0"	12'1"	10'7"	
550S125-33	33	12'10"	11'11"	10'8"	18'6"	17'1"	15'5"	11'7"	10'8"	9'7"	16'7"	15'5"	13'10"	9'5"	8'9"	7'10"	13'6"	12'5"	11'1"	
550S125-43	33	14'2"	13'0"	11'8"	20'0"	18'6"	16'7"	12'7"	11'8"	10'5"	17'11"	16'7"	14'11"	10'2"	9'5"	8'6"	14'7"	13'6"	12'2"	
550S137-27	33	13'8"	12'8"	11'5"	19'9"	18'4"	16'7"	12'4"	11'5"	10'4"	17'10"	16'7"	14'11"	10'1"	9'4"	8'5"	14'8"	13'6"	11'9"	
550S137-30	33	14'1"	13'0"	11'9"	20'3"	18'10"	17'0"	12'8"	11'9"	10'7"	18'3"	17'0"	15'4"	10'4"	9'7"	8'8"	15'0"	13'11"	12'4"	
550S137-33	33	14'6"	13'5"	12'1"	20'10"	19'4"	17'5"	13'0"	12'1"	10'10"	18'9"	17'5"	15'9"	10'8"	9'10"	8'11"	15'5"	14'3"	12'9"	
550S137-43	33	15'11"	14'8"	13'1"	22'7"	20'11"	18'9"	14'2"	13'1"	11'9"	20'3"	18'9"	16'10"	11'6"	10'8"	9'7"	16'6"	15'4"	13'9"	

Ceiling Spans

Allowable Ceiling Spans • Deflection Limit L/240 • Standard Non-Equivalent Products

Section	F _y (ksi)	4 psf						6 psf						13 psf					
		Lateral Support of Compression Flange						Lateral Support of Compression Flange						Lateral Support of Compression Flange					
		Unsupported Joist Spacing (in) o.c.			Midspan Joist Spacing (in) o.c.			Unsupported Joist Spacing (in) o.c.			Midspan Joist Spacing (in) o.c.			Unsupported Joist Spacing (in) o.c.			Midspan Joist Spacing (in) o.c.		
		12	16	24	12	16	24	12	16	24	12	16	24	12	16	24	12	16	24
550S162-33	33	16' 6"	15' 3"	13' 9"	23' 9"	22' 1"	19' 11"	14' 10"	13' 9"	12' 4"	21' 5"	19' 11"	17' 11"	12' 2"	11' 3"	10' 2"	17' 7"	16' 2"	14' 3"
550S162-43	33	18' 0"	16' 7"	14' 11"	25' 8"	23' 9"	21' 4"	16' 1"	14' 11"	13' 4"	23' 1"	21' 4"	19' 3"	13' 1"	12' 1"	10' 11"	18' 10"	17' 6"	15' 6"
600S125-27	33	12' 5"	11' 6"	10' 4"	17' 11"	16' 6"	14' 9"	11' 2"	10' 4"	9' 4"	16' 0"	14' 9"	13' 2"	9' 2"	8' 6"	7' 7"	12' 11"	11' 10"	10' 4"
600S125-30	33	12' 9"	11' 10"	10' 8"	18' 5"	17' 1"	15' 3"	11' 6"	10' 8"	9' 7"	16' 7"	15' 3"	13' 8"	9' 5"	8' 9"	7' 10"	13' 4"	12' 4"	10' 11"
600S125-33	33	13' 2"	12' 3"	11' 0"	18' 11"	17' 7"	15' 10"	11' 10"	11' 0"	9' 10"	17' 0"	15' 10"	14' 2"	9' 8"	8' 11"	8' 1"	13' 10"	12' 9"	11' 5"
600S125-43	33	14' 6"	13' 4"	11' 11"	20' 6"	19' 0"	17' 0"	12' 11"	11' 11"	10' 8"	18' 4"	17' 0"	15' 3"	10' 5"	9' 8"	8' 8"	15' 0"	13' 11"	12' 6"
600S137-27	33	14' 0"	13' 0"	11' 9"	20' 2"	18' 8"	16' 9"	12' 7"	11' 9"	10' 6"	18' 1"	16' 9"	15' 0"	10' 4"	9' 7"	8' 7"	14' 8"	13' 7"	11' 10"
600S137-30	33	14' 5"	13' 4"	12' 0"	20' 10"	19' 3"	17' 3"	13' 0"	12' 0"	10' 10"	18' 8"	17' 3"	15' 6"	10' 7"	9' 10"	8' 10"	15' 2"	14' 0"	12' 5"
600S137-33	33	14' 11"	13' 9"	12' 5"	21' 5"	19' 10"	17' 10"	13' 4"	12' 5"	11' 2"	19' 3"	17' 10"	16' 0"	10' 11"	10' 2"	9' 2"	15' 8"	14' 6"	12' 11"
600S137-43	33	16' 3"	15' 0"	13' 5"	23' 1"	21' 5"	19' 3"	14' 6"	13' 5"	12' 0"	20' 9"	19' 3"	17' 4"	11' 9"	10' 11"	9' 10"	16' 11"	15' 9"	14' 2"
600S162-33	33	16' 11"	15' 8"	14' 1"	24' 5"	22' 8"	20' 5"	15' 2"	14' 1"	12' 8"	22' 0"	20' 5"	18' 5"	12' 5"	11' 7"	10' 5"	18' 0"	16' 8"	14' 9"
600S162-43	33	18' 5"	17' 0"	15' 3"	26' 4"	24' 4"	21' 11"	16' 6"	15' 3"	13' 8"	23' 8"	21' 11"	19' 9"	13' 5"	12' 5"	11' 2"	19' 4"	17' 11"	16' 0"
800S125-33	33	14' 4"	13' 3"	11' 11"	20' 7"	19' 1"	17' 1"	12' 10"	11' 11"	10' 9"	18' 6"	17' 1"	15' 3"	10' 6"	9' 9"	8' 9"	14' 11"	13' 9"	12' 3"
800S125-43	33	15' 7"	14' 5"	12' 11"	22' 2"	20' 7"	18' 6"	13' 11"	12' 11"	11' 7"	19' 11"	18' 6"	16' 8"	11' 4"	10' 6"	9' 5"	16' 4"	15' 1"	13' 6"
800S137-33	33	16' 2"	15' 0"	13' 6"	23' 3"	21' 6"	19' 3"	14' 6"	13' 6"	12' 2"	20' 10"	19' 3"	17' 3"	11' 11"	11' 0"	9' 10"	16' 10"	15' 7"	14' 0"
800S137-43	33	17' 6"	16' 2"	14' 6"	25' 1"	23' 3"	20' 11"	15' 8"	14' 6"	13' 1"	22' 6"	20' 11"	18' 10"	12' 9"	11' 10"	10' 8"	18' 5"	17' 0"	15' 3"
800S162-33	33	18' 4"	17' 0"	15' 4"	26' 5"	24' 5"	21' 11"	16' 6"	15' 4"	13' 10"	23' 8"	21' 11"	19' 7"	13' 6"	12' 6"	11' 3"	19' 2"	17' 9"	15' 10"
800S162-43	33	19' 11"	18' 5"	16' 6"	28' 7"	26' 6"	23' 10"	17' 10"	16' 6"	14' 10"	25' 8"	23' 10"	21' 5"	14' 7"	13' 6"	12' 2"	20' 11"	19' 4"	17' 4"

Allowable Ceiling Spans • Deflection Limit L/360 • Standard Non-Equivalent Products

Section	F _y (ksi)	4 psf						6 psf						13 psf					
		Lateral Support of Compression Flange						Lateral Support of Compression Flange						Lateral Support of Compression Flange					
		Unsupported Joist Spacing (in) o.c.			Midspan Joist Spacing (in) o.c.			Unsupported Joist Spacing (in) o.c.			Midspan Joist Spacing (in) o.c.			Unsupported Joist Spacing (in) o.c.			Midspan Joist Spacing (in) o.c.		
		12	16	24	12	16	24	12	16	24	12	16	24	12	16	24	12	16	24
162S125-18	33	7' 3"	6' 7"	5' 10"	7' 5"	6' 9"	5' 11"	6' 5"	5' 10"	5' 1"	6' 6"	5' 11"	5' 1"	4' 11"	4' 5"	3' 9"	4' 11"	4' 6"	3' 10"
162S125-27	33	8' 6"	7' 8"	6' 9"	8' 6"	7' 8"	6' 9"	7' 5"	6' 9"	5' 10"	7' 5"	6' 9"	5' 10"	5' 9"	5' 2"	4' 6"	5' 9"	5' 2"	4' 6"
162S125-30	33	8' 9"	7' 11"	6' 11"	8' 9"	7' 11"	6' 11"	7' 8"	6' 11"	6' 1"	7' 8"	6' 11"	6' 1"	5' 11"	5' 4"	4' 8"	5' 11"	5' 4"	4' 8"
162S125-33	33	9' 0"	8' 2"	7' 2"	9' 0"	8' 2"	7' 2"	7' 11"	7' 2"	6' 3"	7' 11"	7' 2"	6' 3"	6' 1"	5' 6"	4' 10"	6' 1"	5' 6"	4' 10"
162S137-27	33	8' 10"	8' 0"	7' 0"	8' 10"	8' 0"	7' 0"	7' 9"	7' 0"	6' 2"	7' 9"	7' 0"	6' 2"	6' 0"	5' 5"	4' 9"	6' 0"	5' 5"	4' 9"
162S137-30	33	9' 1"	8' 3"	7' 3"	9' 1"	8' 3"	7' 3"	8' 0"	7' 3"	6' 4"	8' 0"	7' 3"	6' 4"	6' 2"	5' 7"	4' 11"	6' 2"	5' 7"	4' 11"
162S137-33	33	9' 5"	8' 7"	7' 6"	9' 5"	8' 7"	7' 6"	8' 3"	7' 6"	6' 6"	8' 3"	7' 6"	6' 6"	6' 4"	5' 9"	5' 1"	6' 4"	5' 9"	5' 1"
250S125-18	33	8' 5"	7' 9"	6' 11"	10' 3"	9' 3"	8' 1"	7' 6"	6' 11"	6' 2"	8' 11"	8' 1"	7' 0"	6' 0"	5' 6"	4' 10"	6' 10"	6' 0"	4' 11"
250S125-27	33	9' 8"	8' 11"	8' 0"	11' 9"	10' 8"	9' 4"	8' 8"	8' 0"	7' 2"	10' 3"	9' 4"	8' 1"	7' 0"	6' 6"	5' 9"	7' 11"	7' 2"	6' 3"
250S125-30	33	10' 1"	9' 3"	8' 3"	12' 1"	11' 0"	9' 7"	9' 0"	8' 3"	7' 5"	10' 7"	9' 7"	8' 5"	7' 3"	6' 8"	6' 0"	8' 2"	7' 5"	6' 5"
250S125-33	33	10' 6"	9' 8"	8' 7"	12' 6"	11' 4"	9' 11"	9' 4"	8' 7"	7' 8"	10' 11"	9' 11"	8' 8"	7' 6"	6' 11"	6' 2"	8' 5"	7' 8"	6' 8"
250S125-43	33	11' 9"	10' 10"	9' 7"	13' 7"	12' 4"	10' 9"	10' 5"	9' 7"	8' 6"	11' 10"	10' 9"	9' 5"	8' 4"	7' 8"	6' 10"	9' 2"	8' 4"	7' 3"
250S137-27	33	11' 0"	10' 2"	9' 2"	12' 3"	11' 1"	9' 9"	9' 10"	9' 2"	8' 2"	10' 8"	9' 9"	8' 6"	8' 0"	7' 5"	6' 7"	8' 3"	7' 6"	6' 7"
250S137-30	33	11' 5"	10' 6"	9' 5"	12' 8"	11' 6"	10' 0"	10' 2"	9' 5"	8' 5"	11' 0"	10' 0"	8' 9"	8' 3"	7' 8"	6' 9"	8' 6"	7' 9"	6' 9"
250S137-33	33	11' 10"	10' 11"	9' 9"	13' 1"	11' 10"	10' 4"	10' 7"	9' 9"	8' 9"	11' 5"	10' 4"	9' 1"	8' 7"	7' 11"	7' 0"	8' 10"	8' 0"	7' 0"
250S137-43	33	13' 3"	12' 2"	10' 10"	14' 2"	12' 11"	11' 3"	11' 9"	10' 10"	9' 7"	12' 5"	11' 3"	9' 10"	9' 5"	8' 8"	7' 7"	9' 7"	8' 8"	7' 7"
250S162-33	33	13' 6"	12' 5"	10' 10"	13' 8"	12' 5"	10' 10"	12' 0"	10' 10"	9' 6"	12' 0"	10' 10"	9' 6"	9' 3"	8' 5"	7' 4"	9' 3"	8' 5"	7' 4"
250S162-43	33	14' 11"	13' 6"	11' 10"	14' 11"	13' 6"	11' 10"	13' 0"	11' 10"	10' 4"	13' 0"	11' 10"	10' 4"	10' 1"	9' 2"	8' 0"	10' 1"	9' 2"	8' 0"
350S125-18	33	9' 2"	8' 6"	7' 6"	12' 6"	11' 5"	9' 11"	8' 3"	7' 6"	6' 8"	11' 0"	9' 11"	8' 5"	6' 6"	5' 11"	5' 3"	8' 2"	7' 2"	5' 10"
350S125-27	33	10' 7"	9' 9"	8' 9"	14' 11"	13' 9"	12' 0"	9' 5"	8' 9"	7' 9"	13' 3"	12' 0"	10' 6"	7' 7"	7' 1"	6' 4"	10' 2"	9' 3"	7' 9"
350S125-30	33	10' 11"	10' 1"	9' 0"	15' 5"	14' 2"	12' 5"	9' 9"	9' 0"	8' 1"	13' 8"	12' 5"	10' 10"	7' 11"	7' 3"	6' 6"	10' 7"	9' 7"	8' 3"
350S125-33	33	11' 4"	10' 5"	9' 4"	16' 0"	14' 8"	12' 10"	10' 1"	9' 4"	8' 4"	14' 2"	12' 10"	11' 3"	8' 2"	7' 7"	6' 9"	10' 11"	9' 11"	8' 8"
350S125-43	33	12' 7"	11' 7"	10' 4"	17' 7"	16' 0"	13' 11"	11' 2"	10' 4"	9' 2"	15' 4"	13' 11"	12' 2"	9' 0"	8' 3"	7' 5"	11' 10"	10' 9"	9' 5"
350S137-27	33	11' 11"	11' 0"	9' 11"	15' 10"	14' 5"	12' 7"	10' 8"	9' 11"	8' 11"	13' 10"	12' 7"	11' 0"	8' 8"	8' 1"	7' 3"	10' 8"	9' 9"	8' 6"
350S137-30	33	12' 4"	11' 5"	10' 3"	16' 4"	14' 10"	13' 0"	11' 0"	10' 3"	9' 2"	14' 3"	13' 0"	11' 4"	9' 0"	8' 4"	7' 6"	11' 0"	10' 0"	8' 9"
350S137-33	33	12' 9"	11' 10"	10' 7"	16' 11"	15' 4"	13' 5"	11' 5"	10' 7"	9' 6"	14' 9"	13' 5"	11' 9"	9' 3"	8' 7"	7' 8"	11' 5"	10' 4"	9' 1"
350S137-43	33	14' 2"	13' 0"	11' 7"	18' 4"	16' 8"	14' 7"	12' 7"	11' 7"	10' 4"	16' 1"	14' 7"	12' 9"	10' 2"	9' 4"	8' 5"	12' 5"	11' 3"	9' 10"
350S162-33	33	14' 6"	13' 5"	12' 1"	17' 9"	16' 1"	14' 1"	13' 0"	12' 1"	10' 10"	15' 6"	14' 1"	12' 3"	10' 7"	9' 10"	8' 10"	11' 11"	10' 10"	9' 6"
350S162-43	33	16' 0"	14' 9"	13' 2"	19' 3"	17' 6"	15' 3"	14' 3"	13' 2"	11' 9"	16' 10"	15' 3"	13' 4"	11' 6"	10' 8"	9' 7"	13' 0"	11' 10"	10' 4"
362S125-18	33	9' 3"	8' 7"	7' 7"	12' 8"	11' 7"	10' 0"	8' 4"	7' 7"	6' 9"	11' 1"	10' 0"	8' 6"	6' 7"	6' 0"	5' 4"	8' 3"	7' 4"	6' 0"
362S125-27	33	10' 8"	9' 10"	8' 10"	15' 0"	13' 11"	12' 4"	9' 6"	8' 10"	7' 10"	13' 5"	12' 4"	10' 9"	7' 8"	7' 1"	6' 5"	10' 5"	9' 4"	7' 11"
362S125-30	33	11' 0"	10' 2"	9' 1"	15' 6"	14' 4"	12' 9"	9' 10"	9' 1"	8' 2"	13' 11"	12' 9"	11' 2"	8' 0"	7' 4"	6' 7"	10' 10"	9' 10"	8' 5"
362S125-33	33	11' 5"	10' 7"	9' 5"	16' 2"	14' 10"	13' 2"	10' 3"	9' 5"	8' 5"	14' 5"	13' 2"	11' 6"	8' 3"	7' 8"	6' 10"	11' 3"	10' 2"	8' 11"
362S125-43	33	12' 8"	11' 8"	10' 5"	17' 9"	16' 5"	14' 4"	11' 3"	10' 5"	9' 3"	15' 9"	14' 4"	12' 6"	9' 1"	8' 4"	7' 6"	12' 2"	11' 1"	9' 8"

Allowable Ceiling Spans • Deflection Limit L/360 • Standard Non-Equivalent Products

Section	F _y (ksi)	4 psf						6 psf						13 psf					
		Lateral Support of Compression Flange			Lateral Support of Compression Flange			Lateral Support of Compression Flange			Lateral Support of Compression Flange			Lateral Support of Compression Flange			Lateral Support of Compression Flange		
		Unsupported Joist Spacing (in) o.c.		Midspan Joist Spacing (in) o.c.	Unsupported Joist Spacing (in) o.c.		Midspan Joist Spacing (in) o.c.	Unsupported Joist Spacing (in) o.c.		Midspan Joist Spacing (in) o.c.	Unsupported Joist Spacing (in) o.c.		Midspan Joist Spacing (in) o.c.	Unsupported Joist Spacing (in) o.c.		Midspan Joist Spacing (in) o.c.			
12	16	24	12	16	24	12	16	24	12	16	24	12	16	24	12	16	24		
362S137-27	33	12'0"	11'2"	10'0"	16'3"	14'9"	12'11"	10'10"	10'0"	9'0"	14'3"	12'11"	11'3"	8'9"	8'2"	7'4"	11'0"	10'0"	8'9"
362S137-30	33	12'5"	11'6"	10'4"	16'10"	15'3"	13'4"	11'2"	10'4"	9'3"	14'8"	13'4"	11'8"	9'1"	8'5"	7'6"	11'4"	10'4"	9'0"
362S137-33	33	12'11"	11'11"	10'8"	17'4"	15'9"	13'9"	11'6"	10'8"	9'7"	15'2"	13'9"	12'0"	9'4"	8'8"	7'9"	11'9"	10'8"	9'4"
362S137-43	33	14'3"	13'2"	11'8"	18'11"	17'2"	15'0"	12'8"	11'8"	10'5"	16'6"	15'0"	13'1"	10'3"	9'5"	8'6"	12'9"	11'7"	10'1"
362S162-33	33	14'8"	13'7"	12'2"	18'2"	16'6"	14'5"	13'2"	12'2"	10'11"	15'11"	14'5"	12'7"	10'8"	9'11"	8'11"	12'3"	11'2"	9'9"
362S162-43	33	16'2"	14'11"	13'4"	19'10"	18'0"	15'9"	14'5"	13'4"	11'11"	17'3"	15'9"	13'9"	11'8"	10'9"	9'8"	13'4"	12'2"	10'7"
400S125-18	33	9'6"	8'9"	7'10"	13'0"	11'11"	10'5"	8'6"	7'10"	6'11"	11'6"	10'5"	8'11"	6'9"	6'2"	5'6"	8'7"	7'8"	6'4"
400S125-27	33	10'11"	10'1"	9'1"	15'5"	14'3"	12'9"	9'9"	9'1"	8'1"	13'10"	12'9"	11'2"	7'11"	7'4"	6'7"	10'10"	9'9"	8'3"
400S125-30	33	11'4"	10'5"	9'4"	16'0"	14'9"	13'2"	10'1"	9'4"	8'4"	14'3"	13'2"	11'9"	8'2"	7'7"	6'9"	11'5"	10'4"	8'9"
400S125-33	33	11'9"	10'10"	9'8"	16'7"	15'3"	13'8"	10'6"	9'8"	8'8"	14'9"	13'8"	12'2"	8'6"	7'10"	7'0"	11'11"	10'11"	9'4"
400S125-43	33	13'0"	12'0"	10'8"	18'3"	16'10"	15'0"	11'7"	10'8"	9'6"	16'3"	15'0"	13'5"	9'4"	8'7"	7'8"	13'1"	12'0"	10'6"
400S137-27	33	12'4"	11'5"	10'3"	17'7"	16'0"	13'11"	11'1"	10'3"	9'2"	15'4"	13'11"	12'2"	9'0"	8'4"	7'6"	11'10"	10'9"	9'5"
400S137-30	33	12'9"	11'10"	10'7"	18'2"	16'6"	14'5"	11'5"	10'7"	9'6"	15'10"	14'5"	12'7"	9'3"	8'7"	7'9"	12'3"	11'1"	9'9"
400S137-33	33	13'3"	12'3"	10'11"	18'9"	17'0"	14'11"	11'10"	10'11"	9'10"	16'5"	14'11"	13'0"	9'7"	8'11"	8'0"	12'8"	11'6"	10'1"
400S137-43	33	14'7"	13'6"	12'0"	20'5"	18'6"	16'2"	13'0"	12'0"	10'9"	17'10"	16'2"	14'2"	10'6"	9'8"	8'8"	13'9"	12'6"	10'11"
400S162-33	33	15'0"	13'11"	12'6"	19'8"	17'10"	15'7"	13'6"	12'6"	11'2"	17'2"	15'7"	13'7"	10'11"	10'2"	9'1"	13'3"	12'0"	10'6"
400S162-43	33	16'7"	15'3"	13'8"	21'4"	19'5"	16'11"	14'9"	13'8"	12'2"	18'8"	16'11"	14'10"	11'11"	11'0"	9'11"	14'5"	13'1"	11'5"
550S125-27	33	12'1"	11'3"	10'1"	17'6"	16'1"	14'5"	10'11"	10'1"	9'1"	15'7"	14'5"	12'11"	8'11"	8'3"	7'5"	12'7"	11'7"	10'0"
550S125-30	33	12'6"	11'7"	10'5"	17'11"	16'8"	14'11"	11'2"	10'5"	9'4"	16'2"	14'11"	13'4"	9'2"	8'6"	7'8"	13'0"	12'1"	10'7"
550S125-33	33	12'10"	11'11"	10'8"	18'6"	17'1"	15'5"	11'7"	10'8"	9'7"	16'7"	15'5"	13'10"	9'5"	8'9"	7'10"	13'6"	12'5"	11'1"
550S125-43	33	14'2"	13'0"	11'8"	20'0"	18'6"	16'7"	12'7"	11'8"	10'5"	17'11"	16'7"	14'11"	10'2"	9'5"	8'6"	14'7"	13'6"	12'2"
550S137-27	33	13'8"	12'8"	11'5"	19'9"	18'4"	16'7"	12'4"	11'5"	10'4"	17'10"	16'7"	14'11"	10'1"	9'4"	8'5"	14'8"	13'6"	11'9"
550S137-30	33	14'1"	13'0"	11'9"	20'3"	18'10"	17'0"	12'8"	11'9"	10'7"	18'3"	17'0"	15'4"	10'4"	9'7"	8'8"	15'0"	13'11"	12'4"
550S137-33	33	14'6"	13'5"	12'1"	20'10"	19'4"	17'5"	13'0"	12'1"	10'10"	18'9"	17'5"	15'9"	10'8"	9'10"	8'11"	15'5"	14'3"	12'9"
550S137-43	33	15'11"	14'8"	13'1"	22'7"	20'11"	18'9"	14'2"	13'1"	11'9"	20'3"	18'9"	16'10"	11'6"	10'8"	9'7"	16'6"	15'4"	13'9"
550S162-33	33	16'6"	15'3"	13'9"	23'9"	22'1"	19'11"	14'10"	13'9"	12'4"	21'5"	19'11"	17'5"	12'2"	11'3"	10'2"	17'0"	15'5"	13'6"
550S162-43	33	18'0"	16'7"	14'11"	25'8"	23'9"	21'4"	16'1"	14'11"	13'4"	23'1"	21'4"	19'0"	13'1"	12'1"	10'11"	18'6"	16'10"	14'8"
600S125-27	33	12'5"	11'6"	10'4"	17'11"	16'6"	14'9"	11'2"	10'4"	9'4"	16'0"	14'9"	13'2"	9'2"	8'6"	7'7"	11'10"	10'4"	9'0"
600S125-30	33	12'9"	11'10"	10'8"	18'5"	17'1"	15'3"	11'6"	10'8"	9'7"	16'7"	15'3"	13'8"	9'5"	8'9"	7'10"	13'4"	12'4"	10'11"
600S125-33	33	13'2"	12'3"	11'0"	18'11"	17'7"	15'10"	11'10"	11'0"	9'10"	17'0"	15'10"	14'2"	9'8"	8'11"	8'1"	13'10"	12'9"	11'5"
600S125-43	33	14'6"	13'4"	11'11"	20'6"	19'0"	17'0"	12'11"	11'11"	10'8"	18'4"	17'0"	15'3"	10'5"	9'8"	8'8"	15'0"	13'11"	12'6"
600S137-27	33	14'0"	13'0"	11'9"	20'2"	18'8"	16'9"	12'7"	11'9"	10'6"	18'1"	16'9"	15'0"	10'4"	9'7"	8'7"	14'8"	13'7"	11'10"
600S137-30	33	14'5"	13'4"	12'0"	20'10"	19'3"	17'3"	13'0"	12'0"	10'10"	18'8"	17'3"	15'6"	10'7"	9'10"	8'10"	15'2"	14'0"	12'5"
600S137-33	33	14'11"	13'9"	12'5"	21'5"	19'10"	17'10"	13'4"	12'5"	11'2"	19'3"	17'10"	16'0"	10'11"	10'2"	9'2"	15'8"	14'6"	12'11"
600S137-43	33	16'3"	15'0"	13'5"	23'1"	21'5"	19'3"	14'6"	13'5"	12'0"	20'9"	19'3"	17'4"	11'9"	10'11"	9'10"	16'11"	15'9"	14'2"
600S162-33	33	16'11"	15'8"	14'1"	24'5"	22'8"	20'5"	15'2"	14'1"	12'8"	22'0"	20'5"	18'5"	12'5"	11'7"	10'5"	18'0"	16'6"	14'5"
600S162-43	33	18'5"	17'0"	15'3"	26'4"	24'4"	21'11"	16'6"	15'3"	13'8"	23'8"	21'11"	19'9"	13'5"	12'5"	11'2"	19'4"	17'11"	15'9"
800S125-33	33	14'4"	13'3"	11'11"	20'7"	19'1"	17'1"	12'10"	11'11"	10'9"	18'6"	17'1"	15'3"	10'6"	9'9"	8'9"	14'11"	13'9"	12'3"
800S125-43	33	15'7"	14'5"	12'11"	22'2"	20'7"	18'6"	13'11"	12'11"	11'7"	19'11"	18'6"	16'8"	11'4"	10'6"	9'5"	16'4"	15'1"	13'6"
800S137-33	33	16'2"	15'0"	13'6"	23'3"	21'6"	19'3"	14'6"	13'6"	12'2"	20'10"	19'3"	17'3"	11'11"	11'0"	9'10"	16'10"	15'7"	14'0"
800S137-43	33	17'6"	16'2"	14'6"	25'1"	23'3"	20'11"	15'8"	14'6"	13'1"	22'6"	20'11"	18'10"	12'9"	11'10"	10'8"	18'5"	17'0"	15'3"
800S162-33	33	18'4"	17'0"	15'4"	26'5"	24'5"	21'11"	16'6"	15'4"	13'10"	23'8"	21'11"	19'7"	13'6"	12'6"	11'3"	19'2"	17'9"	15'10"
800S162-43	33	19'11"	18'5"	16'6"	28'7"	26'6"	23'10"	17'10"	16'6"	14'10"	25'8"	23'10"	21'5"	14'7"	13'6"	12'2"	20'11"	19'4"	17'4"

Notes:

1. For unbraced sections, allowable moment based on AISI S100-16 with $K_y L_y = K_t L_t =$ listed span. For mid-span braced sections, allowable moment based on AISI S100-16 with $K_y L_y = K_t L_t =$ (listed span)/2.
2. For distortional buckling allowable moment, $k\Phi = 0$.
3. Web crippling calculation based on bearing length = 1 inch.
4. Web crippling and shear capacity have not been reduced for punchouts. If web punchouts occur near supports members must be checked for reduced shear and web crippling in accordance with AISI S100.
5. Safety factors have NOT been modified in accordance with AISI S220-15, B1.
6. Values are for simple span conditions.
7. Moment of inertia for deflection is calculated at the maximum service level stress for the span and load listed. Note that this value may be higher than the effective I_{xx} listed in section property tables.

^a Web stiffeners are required at end reactions.

Web Crippling Conditions

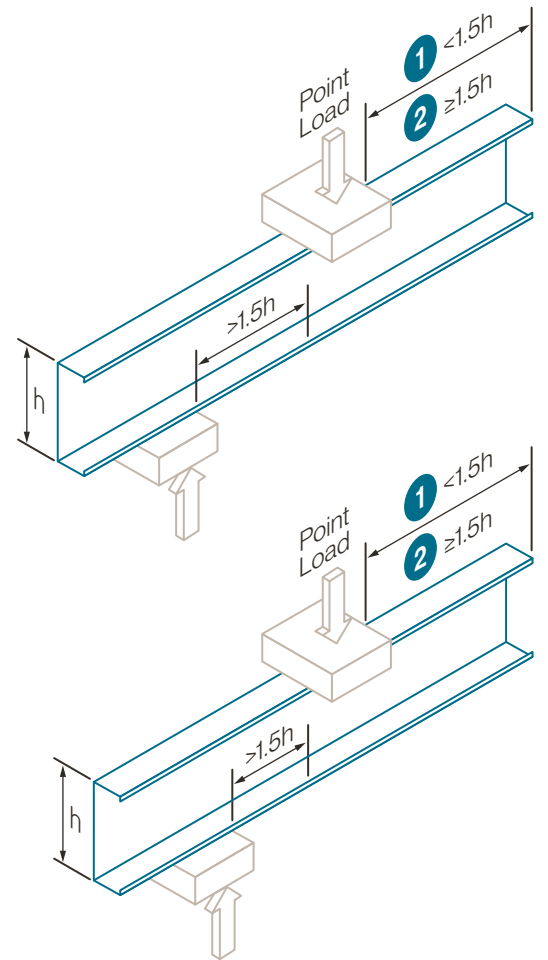
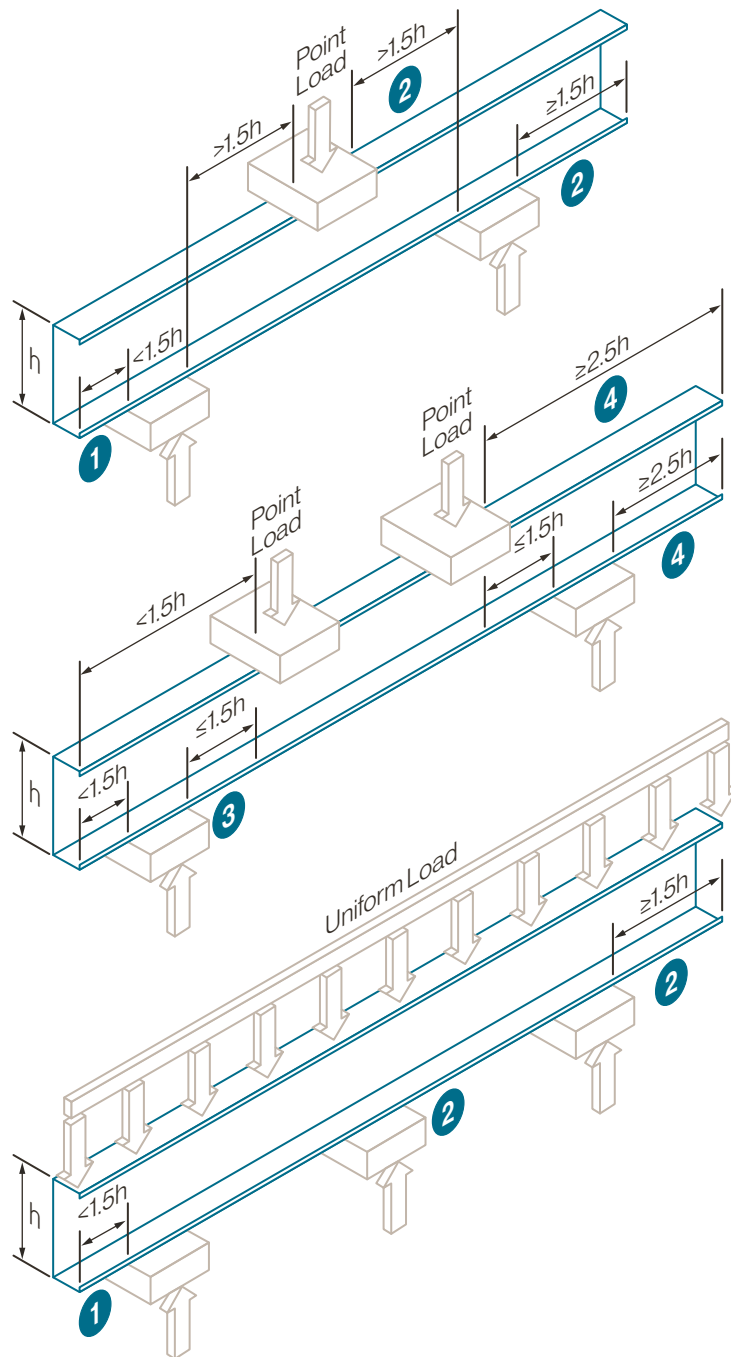

- 1 Condition 1 - End Reaction - One Flange
- 2 Condition 2 - Interior Reaction - One Flange
- 3 Condition 3 - End reaction - Two Flange
- 4 Condition 4 - Interior Reaction - Two Flange

Allowable Web Crippling Loads (lbs) • Standard Non-Equivalent Products

Web Size	Design Thickness (in)	Thickness in mils	Yield Stress (ksi)	Condition 1 Bearing Length (in)				Condition 2 Bearing Length (in)				Condition 3 Bearing Length (in)				Condition 4 Bearing Length (in)			
				1	3.5	4	6	1	3.5	4	6	1	3.5	4	6	1	3.5	4	6
162S-18	0.0188	0.0843	33	55	90 ¹	95 ^{1,2}	112 ^{1,2}	87	125 ¹	131 ^{1,2}	151 ^{1,2}	45	64 ¹	67 ^{1,2}	76 ^{1,2}	122	161 ¹	166 ^{1,2}	186 ^{1,2}
162S-27	0.0283	0.0796	33	122	194 ¹	205 ¹	242 ^{1,2}	218	304 ¹	317 ¹	361 ^{1,2}	111	151 ¹	157 ¹	178 ^{1,2}	290	371 ¹	383 ¹	425 ^{1,2}
162S-30	0.0312	0.0781	33	148	233 ¹	246 ¹	290 ¹	269	373 ¹	388 ¹	442 ¹	137	185 ¹	192 ¹	217 ¹	356	452 ¹	466 ¹	516 ¹
162S-33	0.0346	0.0764	33	180	282 ¹	297 ¹	350 ¹	336	462 ¹	481 ¹	546 ¹	170	229 ¹	237 ¹	267 ¹	441	557 ¹	574 ¹	634 ¹
250S-18	0.0188	0.0843	33	52	84	89 ²	106 ^{1,2}	85	122	128 ²	147 ^{1,2}	37	51	54 ²	61 ^{1,2}	109	145	150 ²	168 ^{1,2}
250S-27	0.0283	0.0796	33	117	186	196	231 ^{1,2}	213	298	310	354 ^{1,2}	96	130	135	153 ^{1,2}	268	343	354	393 ^{1,2}
250S-30	0.0312	0.0781	33	141	223	235	277 ¹	264	366	381	433 ¹	119	161	167	189 ¹	330	420	433	479 ¹
250S-33	0.0346	0.0764	33	173	271	285	336 ¹	330	453	472	535 ¹	150	201	209	235 ¹	411	519	535	591 ¹
350S-18	0.0188	0.0843	33	49	80	84 ²	100 ²	83	119	124 ²	143 ²	28	40	42 ²	48 ²	98	130	134 ²	151 ²
350S-27	0.0283	0.0796	33	112	177	187	221 ²	209	292	304	347 ²	81	111	115	130 ²	247	316	327	362 ²
350S-30	0.0312	0.0781	33	135	214	226	266	259	359	374	425	103	139	144	163	306	389	402	445
350S-33	0.0346	0.0764	33	166	260	274	323	324	445	463	526	131	175	182	205	384	484	499	551
362S-18	0.0188	0.0843	33	49	79	84 ²	99 ²	82	119	124 ²	143 ²	27	39	40 ²	46 ²	97	128	133 ²	149 ²
362S-27	0.0283	0.0796	33	111	177	186	220 ²	209	291	303	346 ²	80	108	113	127 ²	245	313	324	359 ²
362S-30	0.0312	0.0781	33	135	213	224	265	258	358	373	424	101	136	141	160	304	386	398	441
362S-33	0.0346	0.0764	33	165	259	273	322	323	444	462	525	129	173	179	202	381	480	495	547
400S-27	0.0283	0.0796	33	109	174	183	217 ²	207	289	301	344 ²	75	102	106	120 ²	238	305	315	349 ²
400S-30	0.0312	0.0781	33	133	210	221	261	257	356	370	421	95	129	134	151	296	376	388	429
400S-33	0.0346	0.0764	33	163	256	269	317	322	442	460	522	122	164	170	192	372	469	483	534
550S-27	0.0283	0.0796	33	103	164	173	205 ²	202	282	294	336 ²	58	79	82	93 ²	214	274	283	314 ²
550S-30	0.0312	0.0781	33	126	199	210	248	251	348	362	412	76	103	107	120	268	341	351	389
550S-33	0.0346	0.0764	33	155	243	256	302	315	432	450	511	100	134	139	157	339	428	441	487
600S-30	0.0312	0.0781	33	124	196	206	244	249	345	360	409	70	95	98	111	260	330	340	377
600S-33	0.0346	0.0764	33	153	240	253	297	313	430	447	507	93	125	130	146	330	416	429	473

Notes:

1. Web crippling capacities calculated are for studs with stiffened or partially stiffened flanges.
2. Tabulated web crippling capabilities are for single members only. For multiple members, multiply the tabulated values by number of members in the assembly.
3. Listed allowable capacities are based on members "fastened to supports".
4. Listed allowable capacities are for unpunched webs. Capacity reduction for end and interior one flange loading (conditions 1 and 2) near punchouts may be required per Section G6 of S100.

¹Bearing length to web height ratio, N/h exceeds limit of 2.0

²Bearing length to thickness ratio, N/t exceeds limit of 210.

Allowable Screw Connection Capacity (Pounds per Screw)

Thickness (Mils)	Yield Strength F_y (ksi)	Tensile Strength F_u (ksi)	# 6 Screw (0.138" Dia., 1/4" Head)		# 8 Screw (0.164" Dia., 5/16" Head)		# 10 Screw (0.190" Dia., 0.340" Head)		# 12 Screw (0.216" Dia., 0.340" Head)		1/4" Screw (0.250" Dia., 0.409" Head)	
			Shear	Tension	Shear (lbs)	Min Edge Dist (in)	Shear (lbs)	Min Edge Dist (in)	Shear (lbs)	Min Edge Dist (in)	Shear (lbs)	Min Edge Dist (in)
18	33	33	44	24	48	29	52	33	55	38	60	44
27	33	33	82	37	89	43	96	50	102	57	110	66
30	33	33	95	40	103	48	111	55	118	63	127	73
33	33	45	151	61	164	72	177	84	188	95	203	110

Notes:

1. Allowable screw connection capacities are based on Section J4 of the AISI S100-16.
2. When connecting materials of different steel thicknesses or tensile strengths, use the lowest values. Tabulated values assume two sheets of equal thickness are connected.
3. Screw shear and tension capacities was developed using published screw manufacturer data and evaluation reports available at the time of publications.
4. A nominal shear stress of 42.85ksi and a nominal tension stress of 40.84ksi was used for calculations based on screw manufacturer data.
5. Screw capacities are based on Allowable Strength Design (ASD) and include safety factor of 3.0.
6. When multiple fasteners are used, screws are assumed to have a center-to-center spacing of at least 3 times the nominal diameter (d).
7. Screws are assumed to have a center-of-screw to edge-of-steel dimension of at least 1.5 times the nominal diameter (d) of the screw.
8. Tension capacity is based on the lesser of pullout capacity in sheet closest to screw tip, or pullover capacity for sheet closest to screw head (using head diameter).
9. Note that for all tension values calculated in screw table, pullover values have been reduced by 50% assuming eccentrically loaded connections that produce a non uniform pullover force of the fastener.
10. Screw capacities are governed by a conservative estimate of screw capacity, not by sheet steel failure.
11. For higher screw capacities, especially for screw strength, use specific screws from specific manufacturer. See manufacturer's data for specific allowable values and installation instructions.

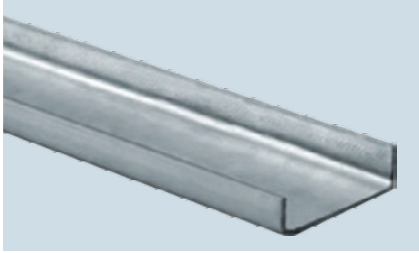

U-Channel

U-Channel is available in 16ga (.054") steel with 1/2" legs. Standard widths are 3/4", 1-1/2" and 2".

Furring (Hat) Channel

Furring (Hat) Channel is available in 7/8" and 1-1/2" heights. Available in 25ga (.018"), 22ga (.027"), 20ga (.030" & .033"), 18ga (.043") and 16ga (.054").

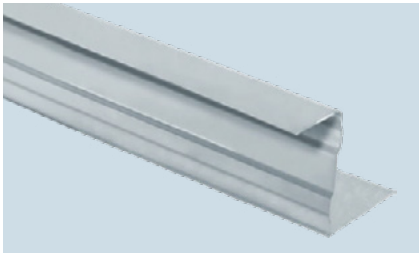
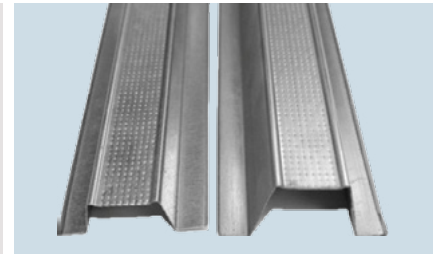

Z-Furring

Z-Furring is available in depths of 1-1/2", 2", 2-1/2", 3" and 4". Available in 25ga (.018"), 22ga (.027"), 20ga (.030" & .033"), 18ga (.043"), 16ga (.054") and 14ga (.068"). *

Resilient Channel (RC-1)

Resilient Channel is available in 25ga (.018") and deluxe version (.024").

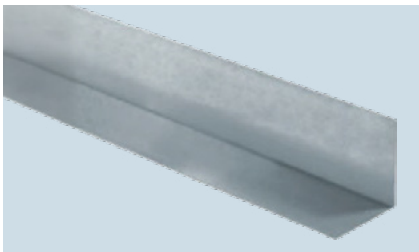
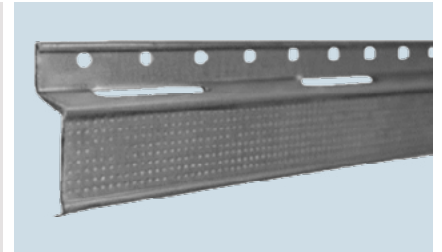

Angle

Angle is available with a 90° bend with 3/4" to 3" legs. Available in 25ga (.018"), 22ga (.027"), 20ga (.030" & .033"), 18ga (.043"), 16ga (.054"), 14ga (.068") and 12ga (.097"). *

Flat Stock

Flat Stock is available from 1-1/2" wide thru 12" wide. Available in 25ga (.018"), 22ga (.027"), 20ga (.030" & .033"), 18ga (.043"), 16ga (.054"), 14ga (.068") and 12ga (.097"). *

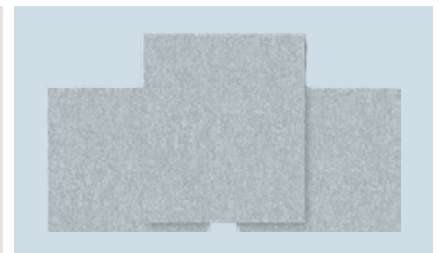

* Custom sizes available.

U-Channel Section Properties

Section	Design Thickness (in)	F _y (ksi)	Gross Properties						33 ksi Effective Properties			
			Area (in ²)	Weight (lb/ft)	I _{xx} (in ⁴)	R _x (in)	I _{yy} (in ⁴)	R _y (in)	I _{xx} (in ⁴)	S _{xx} (in ³)	M _{5-D} (in-k)	V ₅₀ (lb)
075UC-54	0.0566	33	0.087	0.296	0.007	0.289	0.002	0.156	0.007	0.019	0.459	315
150UC-54	0.0566	33	0.130	0.441	0.039	0.549	0.003	0.146	0.039	0.052	1.230	840
200UC-54	0.0566	33	0.158	0.537	0.080	0.711	0.003	0.137	0.080	0.080	1.883	1190

1. Calculated properties are based on AISI S100-16, "North American Specification for Design of Cold-Formed Steel Structure Members."
2. Minimum base metal thickness is 95% of design thickness.
3. Effective properties are based on F_y=33ksi.

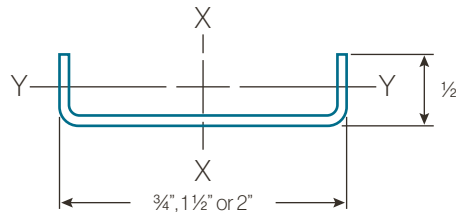

U-Channel Allowable Ceiling Spans • Deflection Limit L/360

Section	Spans	4 psf Channel Spacing (in) o.c.					6 psf Channel Spacing (in) o.c.					13 psf Channel Spacing (in) o.c.					15 psf Channel Spacing (in) o.c.				
		24	36	48	60	72	24	36	48	60	72	24	36	48	60	72	24	36	48	60	72
075UC-54	Single	3'5"	3'0"	2'9"	2'6"	2'4"	3'0"	2'7"	2'4"	2'2"	2'1"	2'4"	2'0"	1'10"	1'8"	1'7"	2'2"	1'11"	1'9"	1'7"	1'6"
	Multiple	4'2"	3'8"	3'4"	3'1"	2'11"	3'8"	3'2"	2'11"	2'8"	2'7"	2'10"	2'6"	2'3"	2'1"	1'11"	2'8"	2'4"	2'2"	2'0"	1'9"
150UC-54	Single	5'6"	4'10"	4'5"	4'1"	3'10"	4'10"	4'3"	3'10"	3'7"	3'5"	3'9"	3'4"	3'0"	2'9"	2'7"	3'7"	3'2"	2'10"	2'7"	2'5"
	Multiple	7'1"	6'2"	5'8"	5'3"	4'11"	6'2"	5'5"	4'11"	4'7"	4'4"	4'10"	4'2"	3'9"	3'4"	3'0"	4'7"	4'0"	3'6"	3'1"	2'9"
200UC-54	Single	5'10"	5'1"	4'8"	4'4"	4'1"	5'1"	4'6"	4'1"	3'10"	3'7"	4'0"	3'6"	3'2"	3'0"	2'10"	3'10"	3'4"	3'1"	2'10"	2'8"
	Multiple	7'5"	6'6"	5'11"	5'6"	5'2"	6'6"	5'8"	5'2"	4'10"	4'7"	5'1"	4'5"	4'0"	3'9"	3'6"	4'10"	4'3"	3'10"	3'7"	3'2"

U-Channel Allowable Ceiling Spans • Deflection Limit L/240

Section	Spans	4 psf Channel Spacing (in) o.c.					6 psf Channel Spacing (in) o.c.					13 psf Channel Spacing (in) o.c.					15 psf Channel Spacing (in) o.c.				
		24	36	48	60	72	24	36	48	60	72	24	36	48	60	72	24	36	48	60	72
075UC-54	Single	3'11"	3'5"	3'1"	2'11"	2'9"	3'5"	3'0"	2'9"	2'6"	2'4"	2'8"	2'4"	2'1"	1'11"	1'9"	2'6"	2'2"	2'0"	1'10"	1'8"
	Multiple	4'10"	4'2"	3'10"	3'7"	3'4"	4'2"	3'8"	3'4"	3'1"	2'10"	3'3"	2'9"	2'4"	2'1"	1'11"	3'1"	2'7"	2'2"	2'0"	1'9"
150UC-54	Single	5'6"	4'10"	4'5"	4'1"	3'10"	4'10"	4'3"	3'10"	3'7"	3'5"	3'9"	3'4"	3'0"	2'9"	2'7"	3'7"	3'2"	2'10"	2'7"	2'5"
	Multiple	7'1"	6'2"	5'8"	5'3"	4'11"	6'2"	5'5"	4'11"	4'7"	4'4"	4'10"	4'2"	3'9"	3'4"	3'0"	4'7"	4'0"	3'6"	3'1"	2'9"
200UC-54	Single	5'10"	5'1"	4'8"	4'4"	4'1"	5'1"	4'6"	4'1"	3'10"	3'7"	4'0"	3'6"	3'2"	3'0"	2'10"	3'10"	3'4"	3'1"	2'10"	2'8"
	Multiple	7'5"	6'6"	5'11"	5'6"	5'2"	6'6"	5'8"	5'2"	4'10"	4'7"	5'1"	4'5"	4'0"	3'9"	3'6"	4'10"	4'3"	3'10"	3'7"	3'2"

U-Channel Allowable Ceiling Spans • Deflection Limit L/120

Section	Spans	4 psf Channel Spacing (in) o.c.					6 psf Channel Spacing (in) o.c.					13 psf Channel Spacing (in) o.c.					15 psf Channel Spacing (in) o.c.				
		24	36	48	60	72	24	36	48	60	72	24	36	48	60	72	24	36	48	60	72
075UC-54	Single	4'10"	4'1"	3'7"	3'3"	3'0"	4'1"	3'5"	3'0"	2'9"	2'6"	2'11"	2'5"	2'2"	1'11"	1'9"	2'9"	2'4"	2'0"	1'10"	1'8"
	Multiple	5'5"	4'6"	4'2"	3'10"	3'5"	4'6"	3'11"	3'5"	3'2"	2'11"	3'5"	2'9"	2'4"	2'1"	1'11"	3'1"	2'7"	2'2"	2'0"	1'9"
150UC-54	Single	5'6"	4'10"	4'5"	4'1"	3'10"	4'10"	4'3"	3'10"	3'7"	3'5"	3'9"	3'4"	3'0"	2'9"	2'7"	3'7"	3'2"	2'10"	2'7"	2'5"
	Multiple	7'1"	6'2"	5'8"	5'3"	4'11"	6'2"	5'5"	4'11"	4'7"	4'4"	4'10"	4'2"	3'9"	3'4"	3'0"	4'7"	4'0"	3'6"	3'1"	2'9"
200UC-54	Single	5'10"	5'1"	4'8"	4'4"	4'1"	5'1"	4'6"	4'1"	3'10"	3'7"	4'0"	3'6"	3'2"	3'0"	2'10"	3'10"	3'4"	3'1"	2'10"	2'8"
	Multiple	7'5"	6'6"	5'11"	5'6"	5'2"	6'6"	5'8"	5'2"	4'10"	4'7"	5'1"	4'5"	4'0"	3'9"	3'6"	4'10"	4'3"	3'10"	3'7"	3'2"

1. Allowable ceiling spans are based on effective properties.
2. Multiple span indicates two or more equal spans with channel continuous over interior supports.
3. Bearing length = 0.75".
4. Table values are based on the compression flange laterally unsupported.

Furring (Hat) Channel Section Properties

Section	Design Thickness (in)	F _y (ksi)	Gross Properties						33 ksi Effective Properties			
			Area (in ²)	Weight (lb/ft)	I _{xx} (in ⁴)	R _x (in)	I _{yy} (in ⁴)	R _y (in)	I _{xx} (in ⁴)	S _{xx} (in ³)	M _{u-D} (ft-lb)	V _u (lb)
087FC-18	0.0188	33	0.080	0.271	0.011	0.365	0.053	0.819	0.009	0.016	26.59	369
087FC-27	0.0283	33	0.118	0.400	0.015	0.362	0.079	0.820	0.015	0.029	47.16	523
087FC-30	0.0312	33	0.129	0.439	0.017	0.360	0.087	0.821	0.017	0.033	53.89	565
087FC-33	0.0346	33	0.142	0.483	0.018	0.359	0.096	0.821	0.018	0.038	61.88	612
087FC-43	0.0451	33	0.181	0.615	0.023	0.356	0.122	0.822	0.023	0.051	83.61	739
150FC-18	0.0188	33	0.103	0.352	0.036	0.591	0.077	0.861	0.032	0.035	57.20	605
150FC-27	0.0283	33	0.153	0.522	0.053	0.587	0.114	0.862	0.051	0.060	98.15	965
150FC-30	0.0312	33	0.168	0.573	0.058	0.585	0.125	0.862	0.057	0.068	111.45	1053
150FC-33	0.0346	33	0.186	0.632	0.063	0.584	0.138	0.862	0.063	0.077	127.26	1153
150FC-43	0.0451	33	0.238	0.810	0.080	0.579	0.177	0.863	0.080	0.104	171.31	1444

Notes:

1. Effective properties are based on AISI S100-16, "North American Specification for Design of Cold-Formed Steel Structure Members" 2016 edition.
2. Design thickness used for determination of properties. Minimum delivered thickness must be no less than 95% of design thickness.
3. For deflection calculations, use the effective moment of inertia, I_{xx}.
4. Effective properties are given as the minimum value for positive or negative bending.

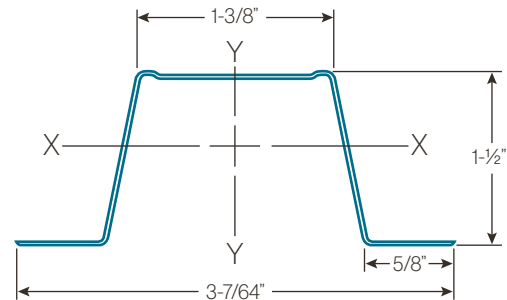
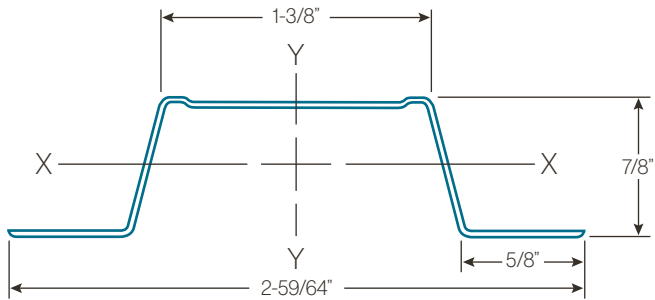

Furring (Hat) Channel Allowable Ceiling Spans • Deflection Limit L/360

Section	F _y (ksi)	Spans	4 psf Channel Spacing (in) o.c.			6 psf Channel Spacing (in) o.c.			13 psf Channel Spacing (in) o.c.		
			12	16	24	12	16	24	12	16	24
087FC-18	33	Single	4'8"	4'3"	3'8"	4'1"	3'8"	3'3"	3'2"	2'10"	2'6"
		Multiple	5'9"	5'3"	4'7"	5'0"	4'7"	4'0"	3'11"	3'6"	2'10"
087FC-27	33	Single	5'6"	5'0"	4'4"	4'9"	4'4"	3'9"	3'8"	3'4"	2'11"
		Multiple	6'9"	6'2"	5'4"	5'11"	5'4"	4'8"	4'7"	4'2"	3'7"
087FC-30	33	Single	5'8"	5'2"	4'6"	5'0"	4'6"	3'11"	3'10"	3'6"	3'0"
		Multiple	7'0"	6'4"	5'7"	6'1"	5'7"	4'10"	4'9"	4'4"	3'9"
087FC-33	33	Single	5'10"	5'4"	4'8"	5'1"	4'8"	4'1"	3'11"	3'7"	3'2"
		Multiple	7'3"	6'7"	5'9"	6'4"	5'9"	5'0"	4'11"	4'5"	3'11"
087FC-43	33	Single	6'4"	5'9"	5'0"	5'6"	5'0"	4'4"	4'3"	3'10"	3'5"
		Multiple	7'9"	7'1"	6'2"	6'10"	6'2"	5'5"	5'3"	4'9"	4'2"
150FC-18	33	Single	7'0"	6'5"	5'7"	6'2"	5'7"	4'10"	4'9"	4'4"	3'9"
		Multiple	8'8"	7'11"	6'11"	7'7"	6'11"	6'0"	5'10"	4'11"	3'10"
150FC-27	33	Single	8'3"	7'6"	6'7"	7'3"	6'7"	5'9"	5'7"	5'1"	4'5"
		Multiple	10'2"	9'3"	8'1"	8'11"	8'1"	7'1"	6'11"	6'3"	5'6"
150FC-30	33	Single	8'7"	7'9"	6'9"	7'6"	6'9"	5'11"	5'9"	5'3"	4'7"
		Multiple	10'7"	9'7"	8'5"	9'3"	8'5"	7'4"	7'2"	6'6"	5'8"
150FC-33	33	Single	8'10"	8'0"	7'0"	7'9"	7'0"	6'2"	6'0"	5'5"	4'9"
		Multiple	10'11"	9'11"	8'8"	9'7"	8'8"	7'7"	7'5"	6'8"	5'10"
150FC-43	33	Single	9'7"	8'8"	7'7"	8'4"	7'7"	6'7"	6'5"	5'10"	5'1"
		Multiple	11'10"	10'9"	9'5"	10'4"	9'5"	8'2"	8'0"	7'3"	6'4"

Furring (Hat) Channel Allowable Ceiling Spans • Deflection Limit L/360

Section	F _y (ksi)	Spans	4 psf Channel Spacing (in) o.c.			6 psf Channel Spacing (in) o.c.			13 psf Channel Spacing (in) o.c.		
			12	16	24	12	16	24	12	16	24
087FC-18	33	Single	5'4"	4'10"	4'3"	4'8"	4'3"	3'8"	3'7"	3'3"	2'10"
	33	Multiple	6'7"	6'0"	5'2"	5'9"	5'2"	4'2"	4'0"	3'6"	2'10"
087FC-27	33	Single	6'3"	5'8"	5'0"	5'6"	5'0"	4'4"	4'3"	3'10"	3'4"
	33	Multiple	7'9"	6'0"	6'2"	6'9"	6'2"	5'4"	5'3"	4'8"	3'10"
087FC-30	33	Single	6'6"	5'11"	5'2"	5'8"	5'2"	4'6"	4'5"	4'0"	3'6"
	33	Multiple	8'0"	7'4"	6'4"	7'0"	6'4"	5'7"	5'5"	4'11"	4'1"
087FC-33	33	Single	6'8"	6'1"	5'4"	5'10"	5'4"	4'8"	4'6"	4'1"	3'7"
	33	Multiple	8'3"	7'6"	6'7"	7'3"	6'7"	5'9"	5'7"	5'1"	4'4"
087FC-43	33	Single	7'3"	6'7"	5'9"	6'4"	5'9"	4'12"	4'10"	4'5"	3'10"
	33	Multiple	9'0"	8'1"	7'1"	7'9"	7'1"	6'2"	6'0"	5'6"	4'9"
150FC-18	33	Single	8'1"	7'4"	6'5"	7'0"	6'5"	5'7"	5'5"	4'11"	4'2"
	33	Multiple	9'11"	9'1"	7'7"	8'8"	7'7"	6'1"	5'10"	4'11"	3'10"
150FC-27	33	Single	9'5"	8'7"	7'6"	8'3"	7'6"	6'7"	6'5"	5'10"	5'1"
	33	Multiple	11'8"	10'7"	9'3"	10'2"	9'3"	8'1"	7'9"	6'9"	5'6"
150FC-30	33	Single	9'10"	8'11"	7'9"	8'7"	7'9"	6'9"	6'7"	6'0"	5'3"
	33	Multiple	12'1"	11'0"	9'7"	10'7"	9'7"	8'5"	8'2"	7'2"	5'10"
150FC-33	33	Single	10'1"	9'2"	8'0"	8'10"	8'0"	7'0"	6'10"	6'2"	5'5"
	33	Multiple	12'6"	11'4"	9'11"	10'11"	9'11"	8'8"	8'5"	7'8"	6'3"
150FC-43	33	Single	10'11"	9'11"	8'8"	9'7"	8'8"	7'7"	7'5"	6'8"	5'10"
	33	Multiple	13'6"	12'3"	10'9"	11'10"	10'9"	9'5"	9'2"	8'4"	7'3"

Notes:

1. Single spans taken as the minimum span based on moment, shear, web crippling or deflection.
2. Multiple spans indicate two or more equal, continuous spans with span length measured support to support.
3. Multiple spans taken as minimum span based on moment, shear, web crippling, deflection combined bending and shear or combined bending and web crippling.
4. Web crippling values based on 1" bearing at end and interior supports.

Z-Furring		
Section	F _y (ksi)	Design Thickness (in)
150ZF-18	33	0.0188
150ZF-27	33	0.0283
150ZF-30	33	0.0312
150ZF-33	33	0.0346
150ZF-43	33	0.0451
150ZF-54	50	0.0566
150ZF-68	50	0.0713
200ZF-18	33	0.0188
200ZF-27	33	0.0283
200ZF-30	33	0.0312
200ZF-33	33	0.0346
200ZF-43	33	0.0451
200ZF-54	50	0.0566
200ZF-68	50	0.0713
250ZF-18	33	0.0188
250ZF-27	33	0.0283
250ZF-30	33	0.0312
250ZF-33	33	0.0346
250ZF-43	33	0.0451
250ZF-54	50	0.0566
250ZF-68	50	0.0713
300ZF-18	33	0.0188
300ZF-27	33	0.0283
300ZF-30	33	0.0312
300ZF-33	33	0.0346
300ZF-43	33	0.0451
300ZF-54	50	0.0566
300ZF-68	50	0.0713
400ZF-18	33	0.0188
400ZF-27	33	0.0283
400ZF-30	33	0.0312
400ZF-33	33	0.0346
400ZF-43	33	0.0451
400ZF-54	50	0.0566
400ZF-68	50	0.0713

Rolled Angles		
Section	F _y (ksi)	Design Thickness (in)
075A-18	33	0.0188
075A-27	33	0.0283
075A-30	33	0.0312
075A-33	33	0.0346
075A-43	33	0.0451
075A-54	50	0.0566
075A-68	50	0.0713
075A-97	50	0.1017
100A-18	33	0.0188
100A-27	33	0.0283
100A-30	33	0.0312
100A-33	33	0.0346
100A-43	33	0.0451
100A-54	50	0.0566
100A-68	50	0.0713
100A-97	50	0.1017
150A-18	33	0.0188
150A-27	33	0.0283
150A-30	33	0.0312
150A-33	33	0.0346
150A-43	33	0.0451
150A-54	50	0.0566
150A-68	50	0.0713
150A-97	50	0.1017
200A-18	33	0.0188
200A-27	33	0.0283
200A-30	33	0.0312
200A-33	33	0.0346
200A-43	33	0.0451
200A-54	50	0.0566
200A-68	50	0.0713
200A-97	50	0.1017
300A-18	33	0.0188
300A-27	33	0.0283
300A-30	33	0.0312
300A-33	33	0.0346
300A-43	33	0.0451
300A-54	50	0.0566
300A-68	50	0.0713
300A-97	50	0.1017

Flat Stock		
Section	F _y (ksi)	Design Thickness (in)
150FS-18	33	0.0188
150FS-27	33	0.0283
150FS-30	33	0.0312
150FS-33	33	0.0346
150FS-43	33	0.0451
150FS-54	50	0.0566
150FS-68	50	0.0713
150FS-97	50	0.1017
200FS-18	33	0.0188
200FS-27	33	0.0283
200FS-30	33	0.0312
200FS-33	33	0.0346
200FS-43	33	0.0451
200FS-54	50	0.0566
200FS-68	50	0.0713
200FS-97	50	0.1017
300FS-18	33	0.0188
300FS-27	33	0.0283
300FS-30	33	0.0312
300FS-33	33	0.0346
300FS-43	33	0.0451
300FS-54	50	0.0566
300FS-68	50	0.0713
300FS-97	50	0.1017
400FS-18	33	0.0188
400FS-27	33	0.0283
400FS-30	33	0.0312
400FS-33	33	0.0346
400FS-43	33	0.0451
400FS-54	50	0.0566
400FS-68	50	0.0713
400FS-97	50	0.1017
500FS-18	33	0.0188
500FS-27	33	0.0283
500FS-30	33	0.0312
500FS-33	33	0.0346
500FS-43	33	0.0451
500FS-54	50	0.0566
500FS-68	50	0.0713
500FS-97	50	0.1017
600FS-18	33	0.0188
600FS-27	33	0.0283
600FS-30	33	0.0312
600FS-33	33	0.0346
600FS-43	33	0.0451
600FS-54	50	0.0566
600FS-68	50	0.0713
600FS-97	50	0.1017
800FS-18	33	0.0188
800FS-27	33	0.0283
800FS-30	33	0.0312
800FS-33	33	0.0346
800FS-43	33	0.0451
800FS-54	50	0.0566
800FS-68	50	0.0713
800FS-97	50	0.1017
1000FS-18	33	0.0188
1000FS-27	33	0.0283
1000FS-30	33	0.0312
1000FS-33	33	0.0346
1000FS-43	33	0.0451
1000FS-54	50	0.0566
1000FS-68	50	0.0713
1000FS-97	50	0.1017
1200FS-18	33	0.0188
1200FS-27	33	0.0283
1200FS-30	33	0.0312
1200FS-33	33	0.0346
1200FS-43	33	0.0451
1200FS-54	50	0.0566
1200FS-68	50	0.0713
1200FS-97	50	0.1017

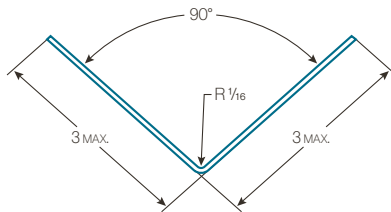
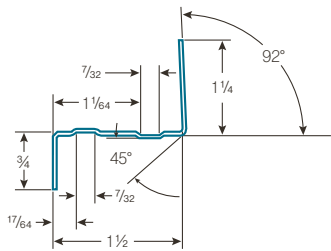

Resilient Channel (RC-1)

Section	F _y (ksi)	Design Thickness (in)
600FS-18	33	0.0188
137RC1-24	33	0.0253

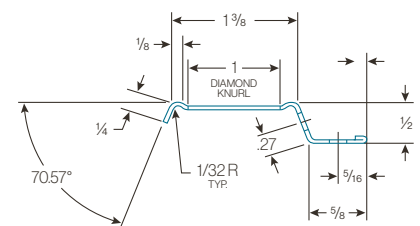

Catalog

Products in this catalog are designed and manufactured for the specific purposes shown and should not be used in other applications unless approved by a qualified design professional. All modifications to products or changes in installation procedures should be approved by a qualified design professional. The performance of such modified products or altered installation procedures is the sole responsibility of the design professional or installation contractor. The installation contractor and/or qualified design professional are responsible for installing all products in accordance with relevant specifications and building codes. MRI has made a concerted effort to ensure the accuracy of the information represented in this catalog. However, this information should not be used in design or construction without an independent evaluation by a qualified engineer or architect.

Loads published on MRI's website and current product catalogs are for the described specific applications of properly installed products. Modifications to MRI products, improper loading or installation procedures, or deviations from recommended applications will affect MRI products' load-carrying capacities. MRI products are fabricated from hot-dipped galvanized steel for corrosion protection but will corrode and lose load-carrying capacity if exposed to salt air, corrosive fire-retardant chemicals, fertilizers, or other substances that may adversely affect steel or its galvanized coating. The current editions of MRI's catalogs and load tables published at <http://www.mristeel framing.com> may reflect changes in the allowable loads and configurations of some of MRI's products.

This information supersedes information in earlier catalogs or technical reports. All earlier catalogs or technical reports should be discarded, and reference made exclusively to the versions available at <http://www.mristeel framing.com>. MRI reserves the right to correct any clerical or typographical errors contained herein. All product sales are subject to MRI's Standard Terms and Conditions of Sale ("MRI Terms") available at <http://www.mristeel framing.com>.

Product Warranty, Liability and Remedy Limitations

The following is a summary of some important limitations included in the MRI Terms. This is not a comprehensive statement of terms and is subject in all respects to the MRI Terms. In the event of any conflict or inconsistency between this summary and the MRI Terms, the MRI Terms shall govern.

MRI warrants solely to customer that, upon shipment, products manufactured by MRI will conform to all published MRI specifications (subject to published MRI or customary industry tolerances and variations) and, for one year following the date of manufacture, such products will be free from defects in materials and workmanship. **OTHER THAN THESE LIMITED WARRANTIES, MRI MAKES NO WARRANTIES, EXPRESS OR IMPLIED, WITH RESPECT TO THE QUALITY OR PERFORMANCE OF ITS PRODUCTS, INCLUDING BUT NOT LIMITED TO THE IMPLIED WARRANTIES OF MERCHANTABILITY AND FITNESS FOR PARTICULAR PURPOSE WHICH ARE DISCLAIMED AND EXCLUDED.**

In no event will MRI's obligation or liability for breach of contract or otherwise exceed the purchase price of any non-conforming or defective Products which are the subject of any dispute between MRI and customer or any third-party claim or cause of action. **MRI SHALL NOT UNDER ANY CIRCUMSTANCES BE LIABLE FOR CONSEQUENTIAL, SPECIAL, EXEMPLARY OR PUNITIVE DAMAGES.**

Customer must complete its inspection of all products for obvious defects immediately upon receipt and for all other matters within 30 days of delivery and may not reject products for any reason other than breach of the limited warranties MRI provides for such products. The customer's sole and exclusive remedy for breach of such limited warranties or otherwise relating to the MRI products shall be for MRI, at its option, to repair or replace, or provide financial accommodations on account of, any products found by MRI or a court of competent jurisdiction to breach such limited warranties. Any claim or cause of action for breach of such limited warranties or otherwise relating to the products must be made or brought, as the case may be, within one year after the claim or cause of action has accrued.

There are other important exclusions to the MRI limited product warranties contained in the MRI Terms. The customer should refer to the MRI Terms for a complete and accurate description of all such exclusions.

Contact Information

MRI Corporate Headquarters

15 Salt Creek Lane, Suite 412
Hinsdale, IL 60521
Phone: (630) 616-1850
Fax: (630) 568-5979

Production Facility

1225 Martin Luther King Dr
Gary, IN 46402
Phone: (630) 616-1850
Fax: (219) 886-3341



www.mristeel framing.com



630-616-1850

MRI Corporate Headquarters

15 Salt Creek Lane, Suite 412
Hinsdale, IL 60521
Phone: (630) 616-1850
Fax: (630) 568-5979



Production Facility

1225 Martin Luther King Dr
Gary, IN 46402
Phone: (630) 616-1850
Fax: (219) 886-3341